

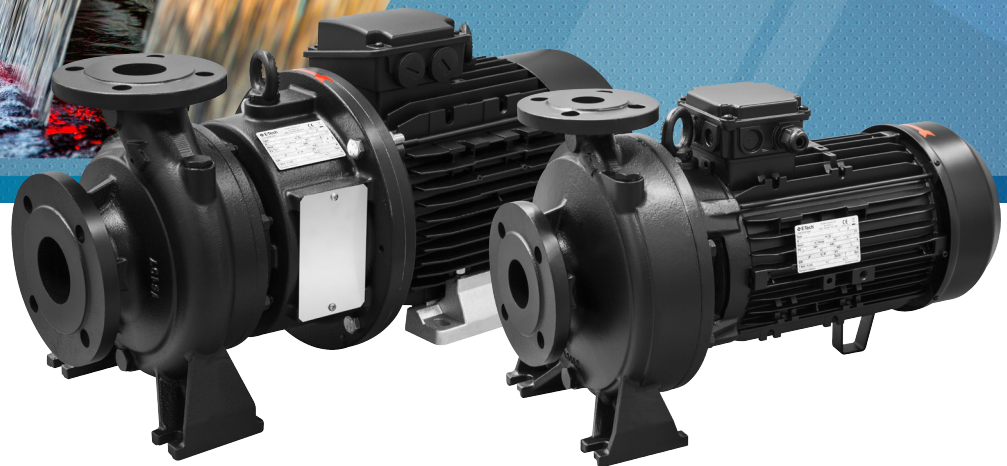

Franklin Electric

FN SERIES 50 Hz

END SUCTION PUMPS EN 733



INDEX

Product Overview	2
Applications	2
Features	2
FNC - Extended Shaft Pumps	2
FNS - Stub Shaft Pumps	3
Family curves	4
Pump identification code	4
Motor specification	5
Mechanical seal specifications	9
Spare parts and materials	10
FNC	10
FNS	11
Technical data and dimensions	12
FNC	13
FNS	15
Hydraulic performance at 50 Hz	17
FNC/FNS - Hydraulic performance at 50 Hz	18
FNC 32-160 - Performance curves	20
FNC/FNS 32-200 - Performance curves	21
FNC/FNS 32-250 - Performance curves	22
FNC 40-125 - Performance curves	23
FNC 40-160 - Performance curves	24
FNC/FNS 40-200 - Performance curves	25
FNC/FNS 40-250 - Performance curves	26
FNC 50-125 - Performance curves	27
FNC/FNS 50-160 - Performance curves	28
FNC/FNS 50-200 - Performance curves	29
FNC/FNS 50-250 - Performance curves	30
FNC/FNS 65-125 - Performance curves	31
FNC/FNS 65-160 - Performance curves	32
FNC/FNS 65-200 - Performance curves	33
FNS 65-250 - Performance curves	34
FNC/FNS 80-160 - Performance curves	35
FNS 80-200 - Performance curves	36
FNS 80-250 - Performance curves	37

Franklin Electric reserves the right to amend specification without prior notice.
 For the most up-to-date product information, visit franklinwater.eu.

PRODUCT OVERVIEW

APPLICATIONS

- Water Distribution
- Water treatment
- Irrigation systems
- Industrial plants

FEATURES

- The FN Series Close-Coupled Centrifugal Electric Pumps are designed for pumping clean and non-explosive or aggressive liquids, designed without abrasive parts and without suspended matter.
- **Maximum liquid temperature**
 - up to 90 °C for domestic use
 - up to 120 °C for industrial use
- **Standard reference**
 - ErP 547/2012 (MEI > 0,4)
 - 640/2009 (Motors efficiency class IE3)
 - UNI EN 733 (DIN 24255)

FNC - EXTENDED SHAFT PUMPS

Close-Coupled Electric Pumps with extended shaft motor.

- **Materials and building features**
 - Pump body / Mechanical seal housing / Motor bracket: Cast-iron GG20 with anti-corrosive coating
 - Suction/delivery ports: according to standard EN1092-2
 - Impeller: Cast-iron GG20 with cataphoresis coating
 - Pump shaft: Stainless steel AISI 304
 - Mechanical seal: Carbon / Ceramic / NBR
- **Pump specification**
 - Flow: up to 180 m³/h
 - Head: up to 90 m
 - Maximum working pressure: PN10
- **Motor specification**
 - Asynchronous squirrel cage-type motor
 - External ventilation
 - The motor protection for three-phase motors must be installed by the customer (Is recommended to use an equipment compliant with current standards)
 - Efficiency class: IE3
 - Insulation class: F
 - Service class: S1
 - Protection: IP54



PRODUCT OVERVIEW

FNS - STUB SHAFT PUMPS

Rigid-coupled with a bracket, an adapter and a rigid coupling keyed to the standard motor shaft extension.

■ Materials and building features

- Pump body / Mechanical seal housing / Motor bracket: Cast-iron GG20 with anti-corrosive coating
- Suction/delivery ports: according to standard EN1092-2
- Impeller: Cast-iron GG20 with cataphoresis coating
- Pump shaft: Stainless steel AISI 304
- Mechanical seal: Carbon / Ceramic / NBR

■ Pump specification

- Flow: up to 240 m³/h
- Head: up to 100 m
- Maximum working pressure: PN10

■ Motor specification

- Type squirrel cage motor, asynchronous with external ventilation
- Motor protection in the three-phase version: on site by the customer (equipment according to the current standards is recommended)
- Efficiency class: IE3
- Insulation class: F
- Service class: S1
- Protection: IP55
- PTC 155 °C probe as standard



FAMILY CURVES

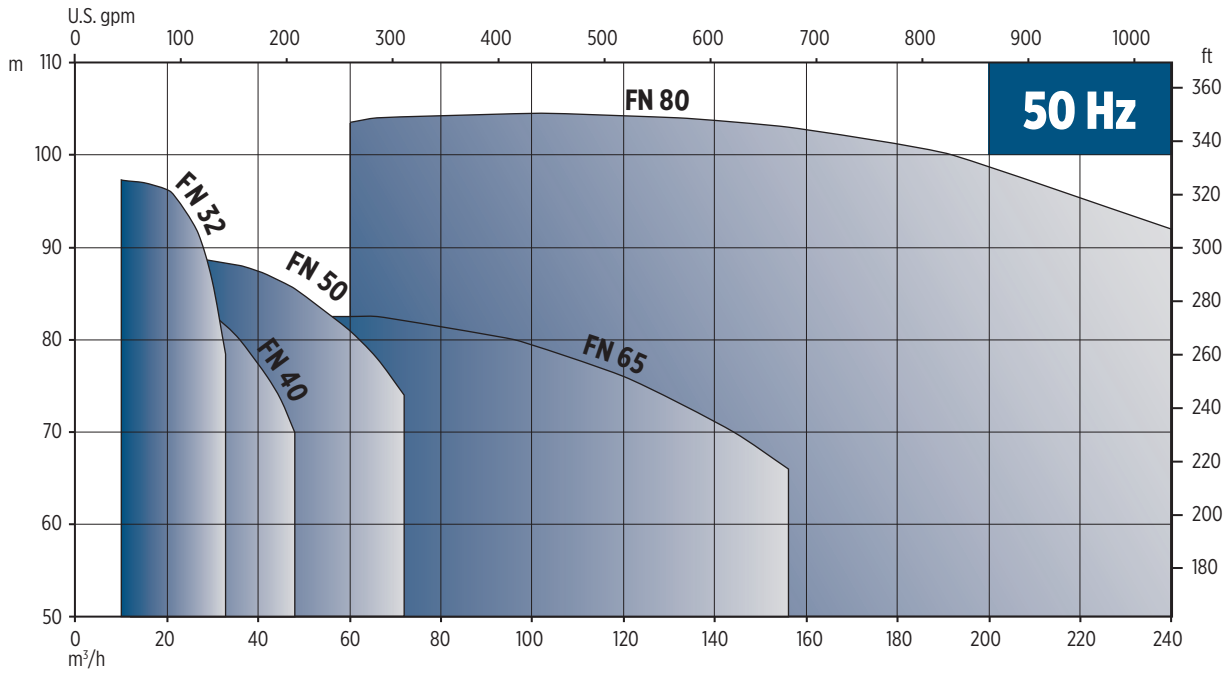

00150140EN 03/2019

PUMP IDENTIFICATION CODE

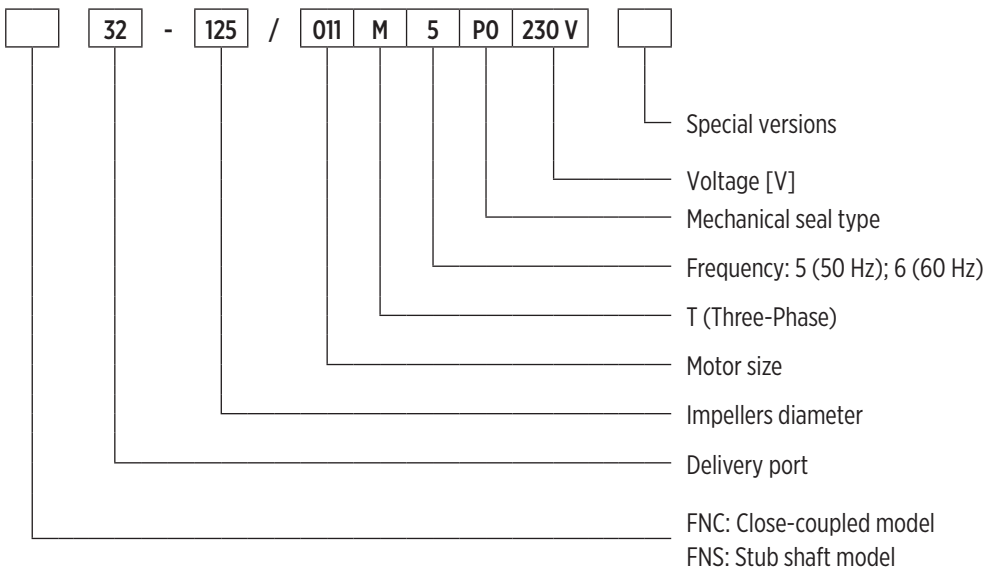

00140059DE 02/2019

MOTOR SPECIFICATION

MOTORS FOR FNC

■ Features

- Protection: IP54
- Maximum ambient temperature: 40 °C
- Insulation class: F

■ Three-phase motors

- High efficiency three-phase motors IE3
- Standard voltage up to 4 kW 230/400 V, 400/690 V from 5.5 kW

Electric pump model	Power P ₂		V nom [V]	μF	η	cos φ	I max [A]	P [kW]	rpm [min ⁻¹]
	[kW]	[HP]							
FNC 32 125	1.1	1.5	230/400	82.7	0.75	4.6	2.6	1.4	2900
	1.5	2	230/400	84.2	0.75	6	3.4	1.7	2900
FNC 32 160	2.2	3	230/400	86.5	0.79	7.9	4.5	2.4	2900
	3	4	230/400	87.1	0.78	12.2	7	3.7	2900
FNC 32 200	4	5.5	230/400	88.1	0.81	13	7.5	5.4	2900
	5.5	7.5	400/690	89.2	0.88	10.5	6.1	6.3	2900
	7.5	10	400/690	90.1	0.89	14.5	8	8.5	2900
FNC 32 250	9.2	12.5	400/690	90.7	0.86	18.1	10.4	10.2	2900
	11	15	400/690	91.2	0.84	21.8	12.7	12.9	2900
	15	20	400/690	91.9	0.86	28.5	16.6	15.3	2900
FNC 40 125	1.5	2	230/400	84.2	0.75	6.3	3.6	2.1	2900
	2.2	3	230/400	86.5	0.79	9.1	5.2	2.7	2900
	3	4	230/400	87.1	0.78	12.1	7	4.1	2900
FNC 40 160	3	4	230/400	87.1	0.78	12.1	7	4.6	2900
	4	5.5	230/400	88.1	0.81	13	7.5	5.3	2900
FNC 40 200	5.5	7.5	400/690	89.2	0.88	10.9	6.4	7.6	2900
	7.5	10	400/690	90.1	0.89	14.5	8	9.5	2900
FNC 40 250	11	15	400/690	91.2	0.84	21.8	12.7	14.3	2900
	15	20	400/690	91.9	0.86	30.1	17.5	18	2900
FNC 50 125	2.2	3	230/400	86.5	0.79	10.1	5.8	3.2	2900
	3	4	230/400	87.1	0.78	12.2	7	4.1	2900
	4	5.5	230/400	88.1	0.81	13	7.5	4.5	2900
FNC 50 160	5.5	7.5	400/690	89.2	0.88	10.9	6.4	5.9	2900
	7.5	10	400/690	90.1	0.89	14.5	8	7.8	2900
FNC 50 200	9.2	12.5	400/690	90.7	0.86	17.1	9.8	10.5	2900
	11	15	400/690	91.2	0.84	21.4	12.4	11.9	2900
	15	20	400/690	91.9	0.86	28.1	16.3	13.9	2900
FNC 50 250	15	20	400/690	91.9	0.86	30.5	17.7	19.9	2900
	18.5	25	400/690	92.4	0.86	34	19.7	22.8	2900
	22	30	400/690	91.9	0.86	41	22.9	24	2940

MOTOR SPECIFICATION

Electric pump model	Power P ₂		V nom [V]	μF	η	cos φ	I max [A]	P ₁ [kW]	rpm [min ⁻¹]
	[kW]	[HP]							
FNC 65 125	5.5	7.5	400/690	89.2	0.88	10.9	6.4	7.2	2900
	7.5	10	400/690	90.1	0.89	13.5	7.8	7.8	2900
FNC 65 160	9.2	12.5	400/690	90.7	0.86	17.6	10.1	10.3	2900
	11	15	400/690	91.2	0.84	21.4	12.4	12.1	2900
	15	20	400/690	91.9	0.86	28.5	16.6	13.7	2900
FNC 65 200	15	20	400/690	91.9	0.86	32	18.6	19.6	2900
	18.5	25	400/690	92.4	0.86	34	19.7	22.2	2900
	22	30	400/690	91.9	0.86	41	22.9	24	2940
FNC 80 160	11	15	400/690	91.2	0.84	21.4	12.4	13.8	2900
	15	20	400/690	91.9	0.86	28.1	16.3	16.4	2900
	18.5	25	400/690	92.4	0.86	34	19.7	19	2900
	22	30	400/690	91.9	0.86	41	22.9	24	2940

MOTORS FOR FNS

■ Features

- AEG Lafert Motors
- Protection: IP55
- Max. ambient temperature: 40 °C
- Insulation class: F
- Dimension: B35

■ Three-phase motors

- High efficiency three-phase motors IE3
- The Standard design includes the following basic features to give a high level of flexibility
- Multi Mount Construction for an easy change of terminal box position
- Terminal box rotates by 90° to allow cable entry from any direction
- Easy-to-change flanges with over-sized and smaller-size dimensions
- Designed for oil seal at drive end to be mounted
- Standard voltage: up to 4 kW 230/400 V, 400/690 V from 5.5 kW

Power P ₂		IEC dim.	Design	I _N [A]			400 V - 50 Hz					
[kW]	[HP]			Δ 400 V	Y 690 V	rpm [min ⁻¹]	M _N [Nm]	D %	cos φ	I _A /I _N	M _A /M _N	Weight [kg]
5.5	7.5	B35	132	10.2	5.9	2920	18.0	89.2	0.90	8.9	3.0	46.0
7.5	10	B35	132	14.4	8.3	2910	24.6	90.1	0.92	8.9	3.0	53.0
9.2	12.5	B35	132	16.5	9.6	2930	30.0	90.7	0.89	10.1	3.7	58.0
11	15	B35	160	19.9	11.5	2950	35.6	91.2	0.89	9.1	4.0	57.8
15	20	B35	160	26.8	15.5	2940	48.7	91.9	0.89	9.7	4.7	88.9
18.5	25	B35	160	33	19.1	2950	59.9	92.4	0.88	10.7	4.6	104
22	30	B35	160	39.4	22.8	2950	71.3	92.7	0.87	10.4	4.5	104
30	40	B35	200	52.7	30.5	2925	97.9	93.3	0.88	6.7	2.4	234
37	50	B35	200	63.3	36.6	2930	120.6	93.7	0.90	6.3	2.3	250
45	60	B35	200	78.5	45.4	2930	146.7	94.0	0.88	6.9	2.3	322
55	75	B35	250	93.5	54	2940	178.6	94.3	0.88	8.0	2.3	420
75	100	B35	280	124.5	72	2940	243.6	94.7	0.92	8.0	2.2	630

MOTOR SPECIFICATION

LAFERT MOTORS SPARE PARTS

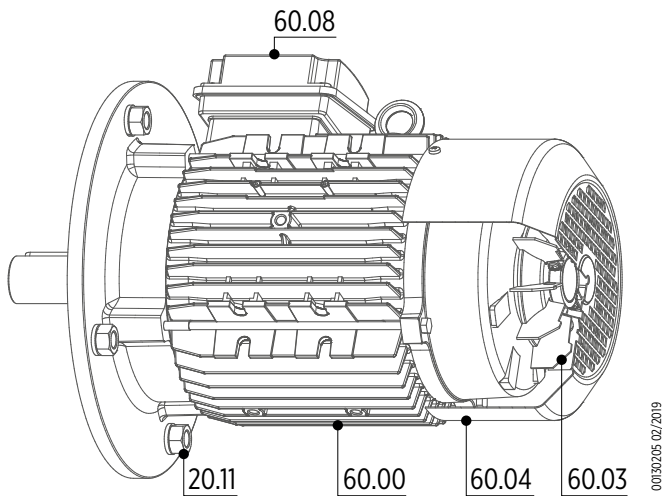

Ref. No	Parts description
20.11	Lifting eyelets and bolts
60.00	Stator
60.03	Fan
60.04	Fan cover and screws
60.08	Terminal box cover and base

NEW INTERNATIONAL EFFICIENCY CLASSES OF MOTORS - IE CODE

The new IEC 60034-30:2008 defines the efficiency classes of motors worldwide.

IE2 = High Efficiency (comparable to EFF1)

IE3 = Premium Efficiency

The efficiency levels according to IEC 60034-30 are measured based on the test methods defined in IEC 60034-2-1:2007.

The IEC 60034-30 standard only defines requirements for efficiency classes and aims to establish provisions for international consistency. It does not define which motors must be supplied with which efficiency level. This is subject to respective regional legislation.

POWER [kW]	IE2 code Standard Efficiency			IE3 code Standard Efficiency		
	2 poles	4 poles	6 poles	2 poles	4 poles	6 poles
0.75	77.4	79.6	75.9	80.7	82.5	78.9
1.1	79.6	81.4	78.1	82.7	84.1	81
1.5	81.3	82.8	79.8	84.2	85.3	82.5
2.2	83.2	84.3	81.8	85.9	86.7	84.3
3	84.6	85.5	83.3	87.1	87.7	85.6
4	85.8	86.6	84.6	88.1	88.6	86.8
5.5	87	87.7	86	89.2	89.6	88
7.5	88.1	88.7	87.2	90.1	90.4	89.1
11	89.4	89.8	88.7	91.2	91.4	90.3
15	90.3	90.6	89.7	91.9	92.1	91.2
18.5	90.9	91.2	90.4	92.4	92.6	91.7
22	91.3	91.6	90.9	92.7	93	92.2
30	92	92.3	91.7	93.3	93.6	92.9
37	92.5	92.7	92.2	93.7	93.9	93.3
45	92.9	93.1	92.7	94	94.2	93.7

Efficiency values according to IEC 60034-30:2008.

Efficiency standard calculation: IEC 60034-2-1:2007

MOTOR SPECIFICATION

NOISE

The noise level of an electrical machine is determined by measuring the sound pressure level in accordance with curve A of the sound level meter to EN 60651 and is indicated in dB (A). The permitted noise levels of electrical machines are fixed in EN 60034-9 (IEC 34-9). The noise level of the motors is below these limit values. Structure-borne sound measurements are carried out in an anechoic testing chamber to EN 21680-ISO 1680. The speed is corresponding to a main frequency of 50 Hz and the number of poles.

Noise levels

The noise values listed below refer to 50 Hz at rated voltage with a tolerance of up to +3 dB (A). Values for pole-changing motors are available on request. For 60 Hz supply, the values are 3-5 dB (A) higher. Sound pressure level (L_{pA}) and sound power level (L_{WA}) refers to three-phase motors with single-speed, dimensions and output ratings as per IEC 60072.

IEC dim.	2 poles		4 poles	
	L _{WA}	L _{pA}	L _{WA}	L _{pA}
56	57	48	47	38
63	58	49	47	38
71	61	52	51	42
80	72	60	60	48
90	74	62	61	49
100	78	66	62	50
112	80	68	65	53
132	81	72	71	59
160	87	74	75	62
180	90	77	78	66
200	91	78	80	68
225	92	80	88	76



MECHANICAL SEAL SPECIFICATIONS

(in accordance with EN 12756)

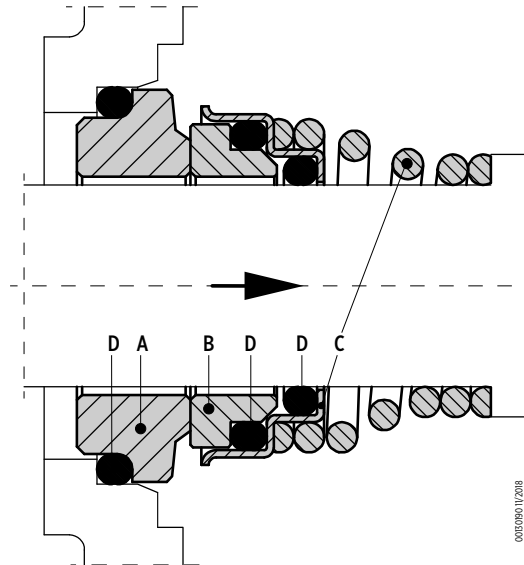

STANDARD VERSION

Model	Type				Position				Temperature [°C]
					A Stationary part	B Rotating part	C Other components	D Elastomers	
PO	V	B	G	P	Ceramic	Graphite	AISI 316	NBR	-10 / +90

AVAILABLE ON REQUEST

Model	Type				Position				Temperature [°C]
					A Stationary part	B Rotating part	C Other components	D Elastomers	
E1	Q	B	G	E	Silicon carbide	Graphite	AISI316	EPDM	-20 / +120
E5	U	U	G	E	Tungsten carbide	Tungsten carbide	AISI316	EPDM	-20 / +120
E7	Q	U	G	E	Tungsten carbide	Silicon carbide	AISI316	EPDM	-20 / +120
V4	Q	B	G	V	Graphite	Silicon carbide	AISI316	FKM	-20 / +120
V6	U	U	G	V	Tungsten carbide	Tungsten carbide	AISI316	FKM	-20 / +120
V8	Q	U	G	V	Tungsten carbide	Silicon carbide	AISI316	FKM	-20 / +120

Sealing Surfaces	
Type	Material
V	Ceramic
B	Graphite
Q	Silicon carbide
U	Tungsten carbide
G	AISI 316
Elastomers	
Type	Material
P	NBR
E	EPDM
V	FKM

Diameter mechanical seal shaft - Standard EN 12756		E1	V4	E7	V8	E5	V6
Motor size [kW]	Shaft diameter [mm]	QBGE	QBGV	QUGE	QUGV	UUGE	UUGV
1.1 / 4	20	●	●	●	●	-	-
5.5 / 7.5	24	●	●	●	●	-	-
9.2 / 22	30	●	●	●	●	-	-
30 / 75	40	-	-	-	-	●	●

● = available

“-” = not available

SPARE PARTS AND MATERIALS

FNC

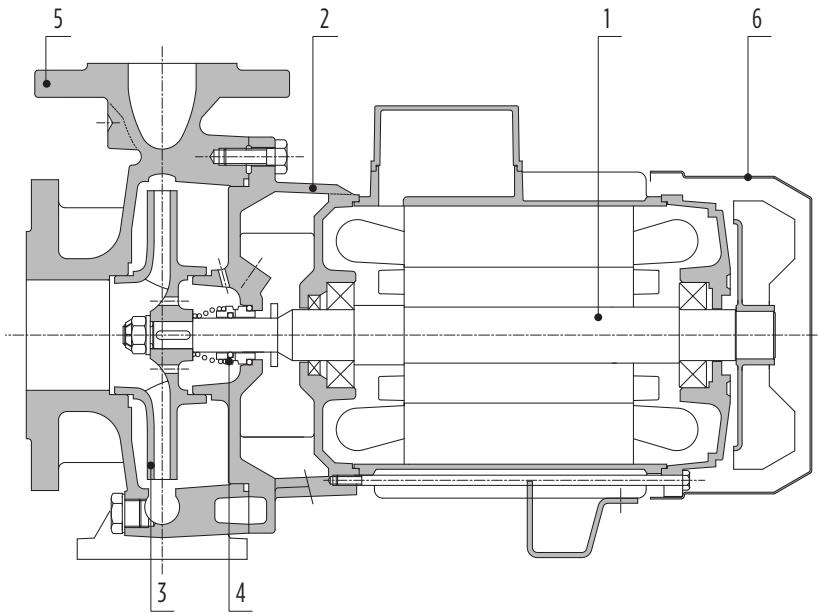

00130194 05/2020

Ref. No	Parts description	Material
1	Pump shaft (part in contact with liquid)	AISI 304
2	Motor bracket	Cast iron GJL200
3	Impeller	Cast iron GJL200
4	Mechanical seal	Carbon / Ceramic / NBR
5	Pump body	Cast iron GJL200
6	Stator	Aluminium

SPARE PARTS AND MATERIALS

FNS

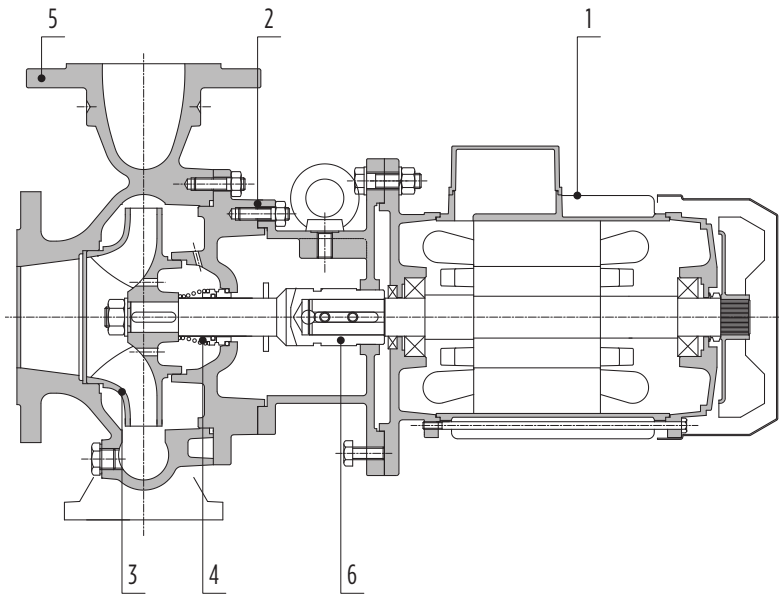

00130195 12/2018

Ref. No	Parts description	Material
1	Motor	See section "Motor specification"
2	Motor bracket	Cast iron GJL200
3	Impeller	Cast iron GJL200
4	Mechanical seal	Carbon / Ceramic / NBR
5	Pump body	Cast iron GJL200
6	Coupling	AISI 303

Technical data and dimensions



TECHNICAL DATA AND DIMENSIONS

FNC

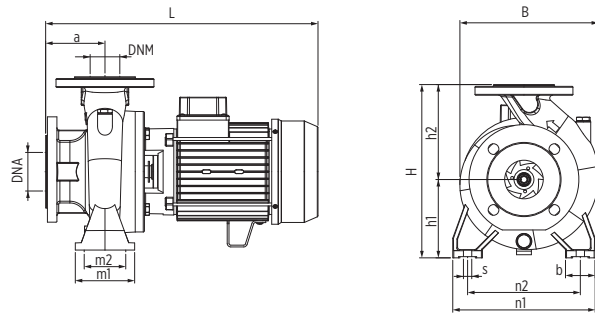

Flange					
DIMENSIONS [mm]				Holes	
DN	K	D	B	n°	Ø
32	100	140	18	4	18
40	110	150	18	4	18
50	125	165	19	4	18
65	145	185	19	4	18
80	160	200	22	8	18
100	180	220	24	8	18

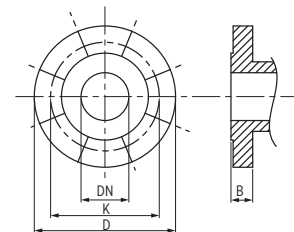

0005093 11/2018

Electric pump model	DIMENSIONS [mm]													
	DNA	DNM	a	b	s	L	B	H	n1	n2	m1	m2	h1	h2
FNC 32-125/011	50	32	80	50	14	400	203	252	190	140	100	70	112	140
FNC 32-125/015	50	32	80	50	14	400	203	252	190	140	100	70	112	140
FNC 32-160/022	50	32	80	50	14	437	240	292	240	190	100	70	132	160
FNC 32-160/030	50	32	80	50	14	400	240	292	240	190	100	70	132	160
FNC 32-200/040	50	32	80	50	14	468	273	340	240	190	100	70	160	180
FNC 32-200/055	50	32	80	50	14	495	273	340	240	190	100	70	160	180
FNC 32-200/075	50	32	80	50	14	537	273	340	240	190	100	70	160	180
FNC 32-250/092	50	32	100	65	14	561	326	405	320	250	125	95	180	225
FNC 32-250/110	50	32	100	65	14	600	326	405	320	250	125	95	180	225
FNC 32-250/150	50	32	100	65	14	682	326	405	320	250	125	95	180	225
FNC 40-125/015	65	40	80	50	14	400	216	252	210	160	100	70	112	140
FNC 40-125/022	65	40	80	50	14	437	216	252	210	160	100	70	112	140
FNC 40-125/030	65	40	80	50	14	463	216	252	210	160	100	70	112	140
FNC 40-160/030	65	40	80	50	14	463	242	292	240	190	100	70	132	160
FNC 40-160/040	65	40	80	50	14	463	242	292	240	190	100	70	132	160
FNC 40-200/055	65	40	100	50	14	515	278	340	265	212	100	70	160	180
FNC 40-200/075	65	40	100	50	14	557	278	340	265	212	100	70	160	180
FNC 40-250/110	65	40	100	65	14	600	328	405	320	250	125	95	180	225
FNC 40-250/150	65	40	100	65	14	682	328	405	320	250	125	95	180	225
FNC 50-125/022	65	50	100	50	14	457	248	292	240	190	100	70	132	160
FNC 50-125/030	65	50	100	50	14	483	248	292	240	190	100	70	132	160
FNC 50-125/040	65	50	100	50	14	483	248	292	240	190	100	70	132	160
FNC 50-160/055	65	50	100	50	14	515	268	340	265	212	100	70	160	180
FNC 50-160/075	65	50	100	50	14	557	268	340	265	212	100	70	160	180
FNC 50-200/092	65	50	100	50	14	561	290	360	265	212	100	70	160	200
FNC 50-200/110	65	50	100	50	14	600	290	360	265	212	100	70	160	200
FNC 50-200/150	65	50	100	50	14	682	290	360	265	212	100	70	160	200
FNC 50-250/150	65	50	100	65	14	682	334	405	320	250	125	95	180	225
FNC 50-250/185	65	50	100	65	14	682	334	405	320	250	125	95	180	225
FNC 50-250/220	65	50	100	65	14	726	334	405	320	250	125	95	180	225
FNC 65-125/055	80	65	100	65	14	515	283	340	280	212	125	95	160	180

Electric pump model	DIMENSIONS [mm]													
	DNA	DNM	a	b	s	L	B	H	n1	n2	m1	m2	h1	h2
FNC 65-125/075	80	65	100	65	14	557	283	340	280	212	125	95	160	180
FNC 65-160/092	80	65	100	65	14	565	290	360	280	212	125	95	160	200
FNC 65-160/110	80	65	100	65	14	605	290	360	280	212	125	95	160	200
FNC 65-160/150	80	65	100	65	14	686	290	360	280	212	125	95	160	200
FNC 65-200/150	80	65	100	65	14	686	330	405	320	250	125	95	180	225
FNC 65-200/185	80	65	100	65	14	686	330	405	320	250	125	95	180	225
FNC 65-200/220	80	65	100	65	14	730	330	405	320	250	125	95	180	225
FNC 80-160/110	100	80	125	65	14	628	330	405	320	250	125	95	180	225
FNC 80-160/150	100	80	125	65	14	710	330	405	320	250	125	95	180	225
FNC 80-160/185	100	80	125	65	14	710	330	405	320	250	125	95	180	225
FNC 80-160/220	100	80	125	65	14	755	330	405	320	250	125	95	180	225



TECHNICAL DATA AND DIMENSIONS

FNS

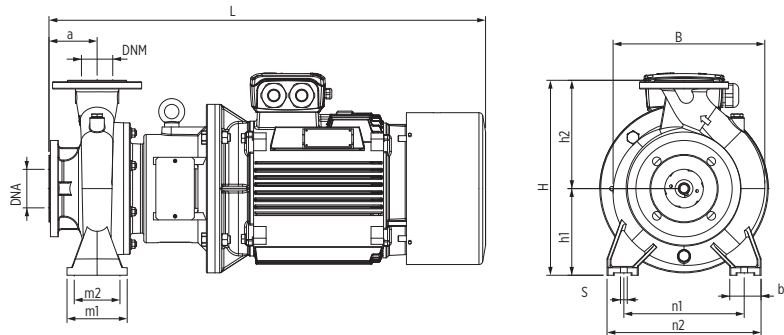

Flange					
DIMENSIONS [mm]				Holes	
DN	K	D	B	n°	Ø
32	100	140	18	4	18
40	110	150	18	4	18
50	125	165	19	4	18
65	145	185	19	4	18
80	160	200	22	8	18
100	180	220	24	8	18

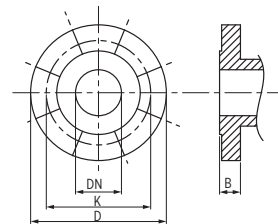

01030192/1/2018

Electric pump model	IEC Size	DIMENSIONS [mm]													
		DNA	DNM	a	b	s	L	B	H	n1	n2	m1	m2	h1	h2
FNS 32-200/055	132	50	32	80	50	14	638	273	340	240	190	100	70	160	180
FNS 32-200/075	132	50	32	80	50	14	658	273	340	240	190	100	70	160	180
FNS 32-250/092	132	50	32	100	65	14	751	326	405	320	250	125	95	180	225
FNS 32-250/110	160	50	32	100	65	14	824	326	405	320	250	125	95	180	225
FNS 32-250/150	160	50	32	100	65	14	824	326	405	320	250	125	95	180	225
FNS 40-200/055	132	65	40	100	50	14	643	278	340	265	212	100	70	160	180
FNS 40-200/075	132	65	40	100	50	14	663	278	340	265	212	100	70	160	180
FNS 40-250/110	160	65	40	100	65	14	826	328	405	320	250	125	95	180	225
FNS 40-250/150	160	65	40	100	65	14	826	328	405	320	250	125	95	180	225
FNS 50-160/055	132	65	50	100	50	14	633	268	340	265	212	100	70	160	180
FNS 50-160/075	132	65	50	100	50	14	653	268	340	265	212	100	70	160	180
FNS 50-200/092	132	65	50	100	50	14	715	290	360	265	212	100	70	160	200
FNS 50-200/110	160	65	50	100	50	14	788	290	360	265	212	100	70	160	200
FNS 50-200/150	160	65	50	100	50	14	788	290	360	265	212	100	70	160	200
FNS 50-250/150	160	65	50	100	65	14	832	334	405	320	250	125	95	180	225
FNS 50-250/185	160	65	50	100	65	14	876	334	405	320	250	125	95	180	225
FNS 50-250/220	180	65	50	100	65	14	876	334	405	320	250	125	95	180	225
FNS 65-125/055	132	80	65	100	65	14	648	283	340	280	212	125	95	160	180
FNS 65-125/075	132	80	65	100	65	14	668	283	340	280	212	125	95	160	180
FNS 65-160/092	132	80	65	100	65	14	715	290	360	280	212	125	95	160	200
FNS 65-160/110	160	80	65	100	65	14	788	290	360	280	212	125	95	160	200
FNS 65-160/150	160	80	65	100	65	14	788	290	360	280	212	125	95	160	200
FNS 65-200/150	160	80	65	100	65	14	828	330	405	320	250	125	95	180	225
FNS 65-200/185	160	80	65	100	65	14	872	330	405	320	250	125	95	180	225
FNS 65-200/220	180	80	65	100	65	14	872	330	405	320	250	125	95	180	225
FNS 65-250/300	200	80	65	100	80	18	1033	375	450	360	280	160	120	200	250
FNS 65-250/370	200	80	65	100	80	18	1033	375	450	360	280	160	120	200	250
FNS 80-160/110	160	100	80	125	65	14	828	330	405	320	250	125	95	180	225
FNS 80-160/150	160	100	80	125	65	14	828	330	405	320	250	125	95	180	225
FNS 80-160/185	160	100	80	125	65	14	872	330	405	320	250	125	95	180	225
FNS 80-160/220	180	100	80	125	65	14	872	330	405	320	250	125	95	180	225
FNS 80-200/300	200	100	80	125	65	18	1028	370	430	345	280	125	95	180	250
FNS 80-200/370	200	100	80	125	65	18	1028	370	430	345	280	125	95	180	250

Electric pump model	IEC Size	DIMENSIONS [mm]													
		DNA	DNM	a	b	s	L	B	H	n1	n2	m1	m2	h1	h2
FNS 80-250/450	225	100	80	125	80	18	1119	420	480	400	315	160	120	200	280
FNS 80-250/550	250	100	80	125	80	18	1198	420	480	400	315	160	120	200	280
FNS 80-250/750	280	100	80	125	80	18	1264	420	480	400	315	160	120	200	280



Hydraulic performance at 50 Hz

FNC 32-125 - PERFORMANCE CURVES

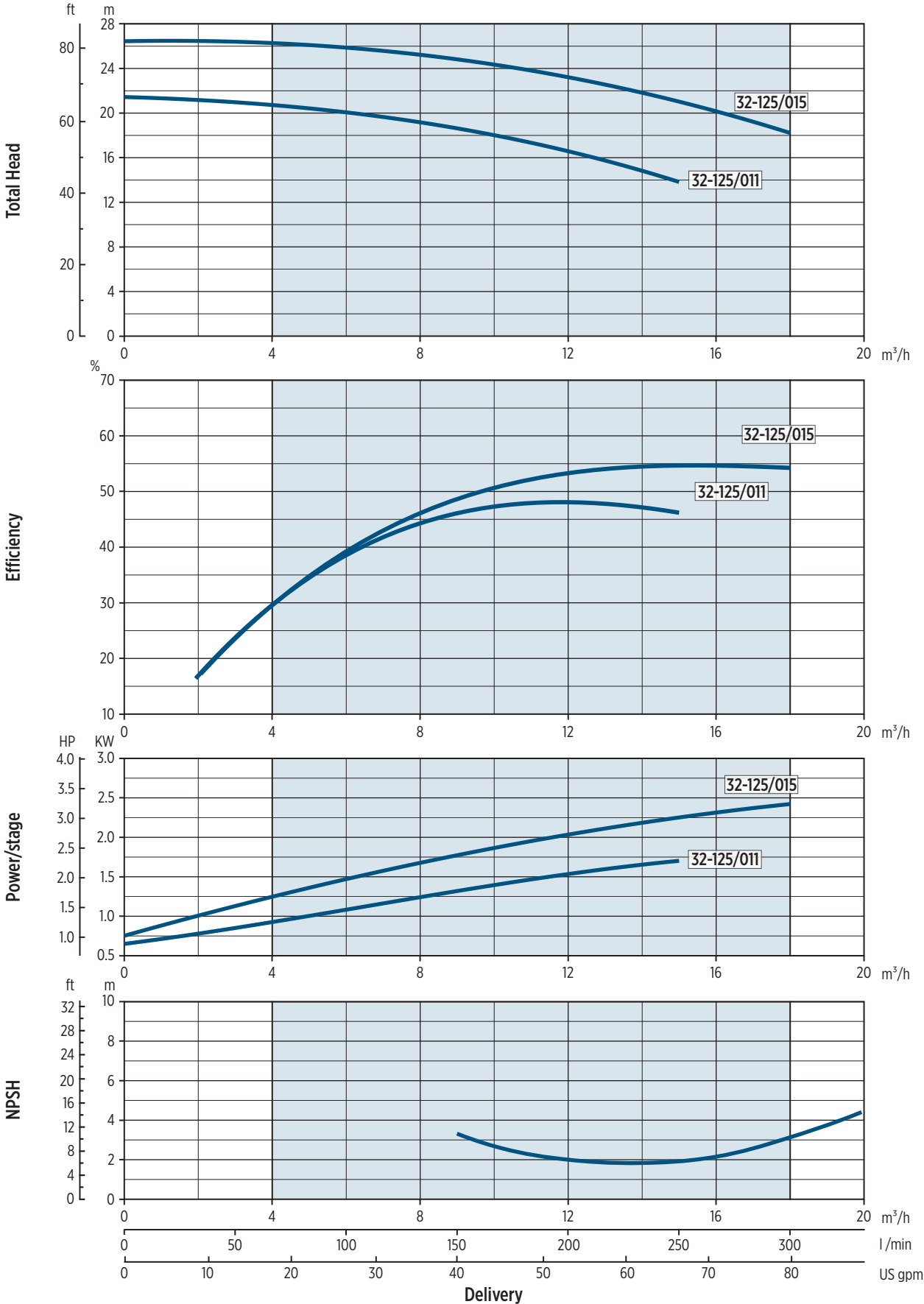

00120182 05/2020

FNC 32-160 - PERFORMANCE CURVES

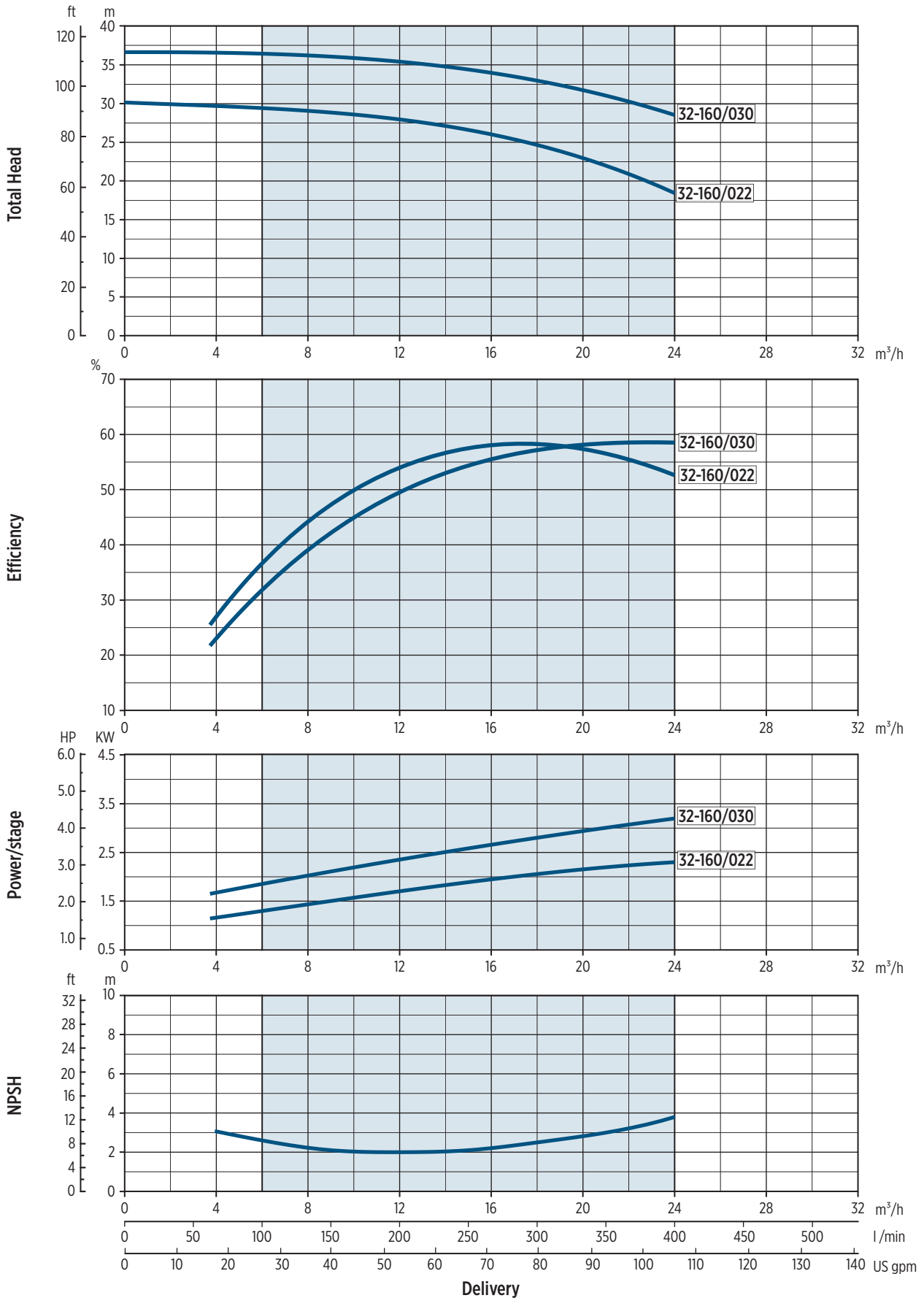

002085EN 02/2019



FNC/FNS 32-200 - PERFORMANCE CURVES

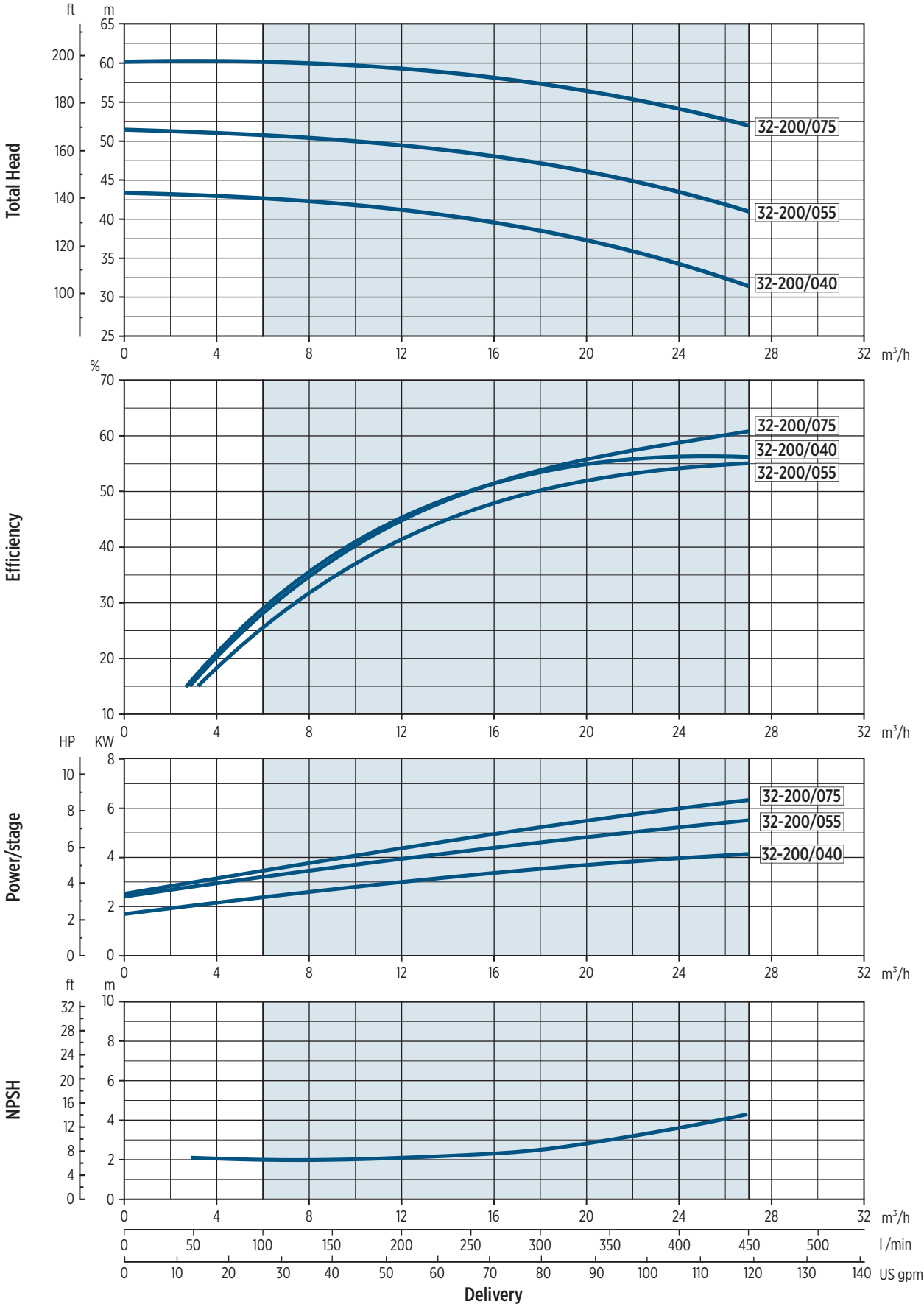

00120204-02/2019

FNC/FNS 32-250 - PERFORMANCE CURVES

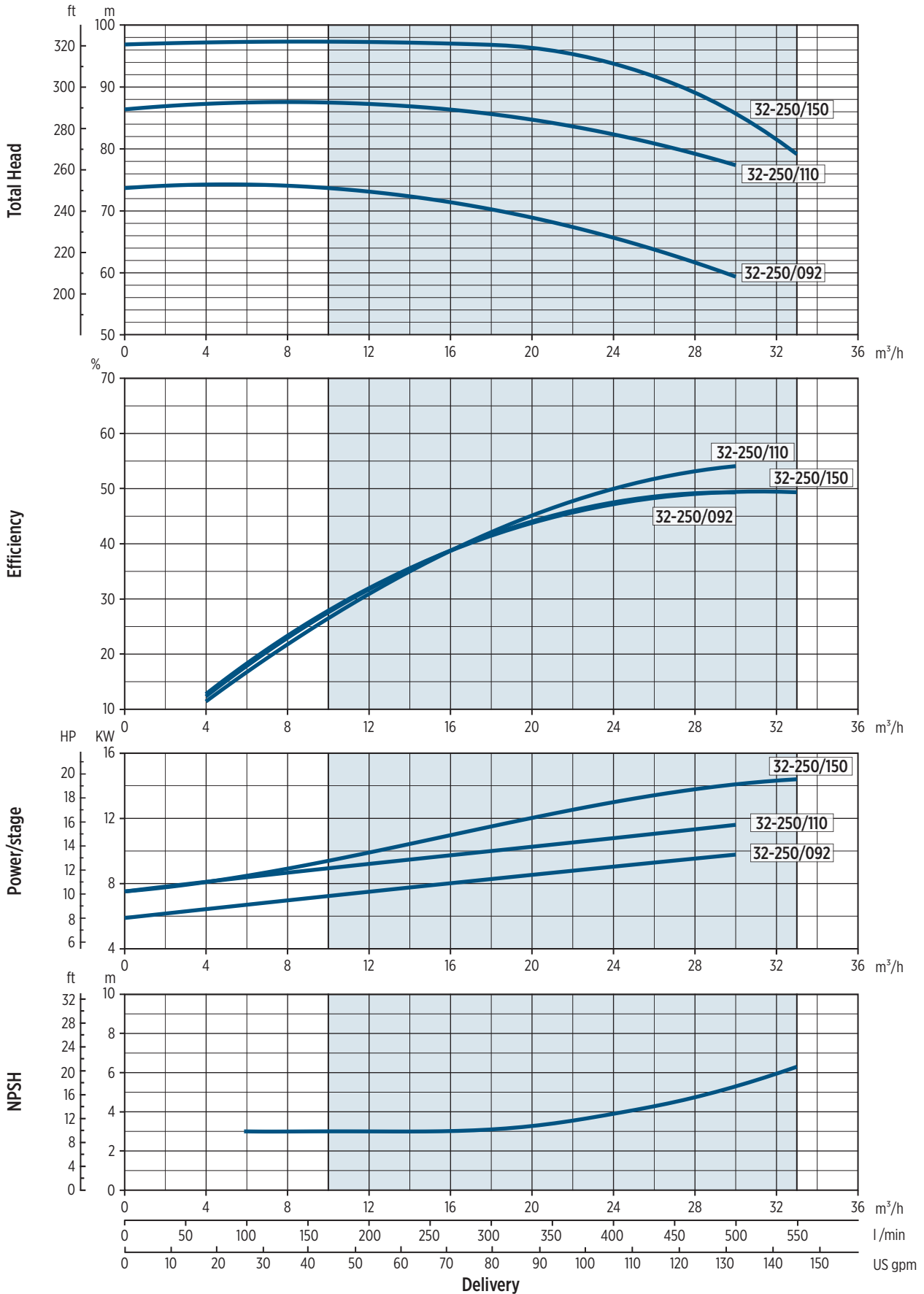

00120205 02/2019



FNC 40-125 - PERFORMANCE CURVES

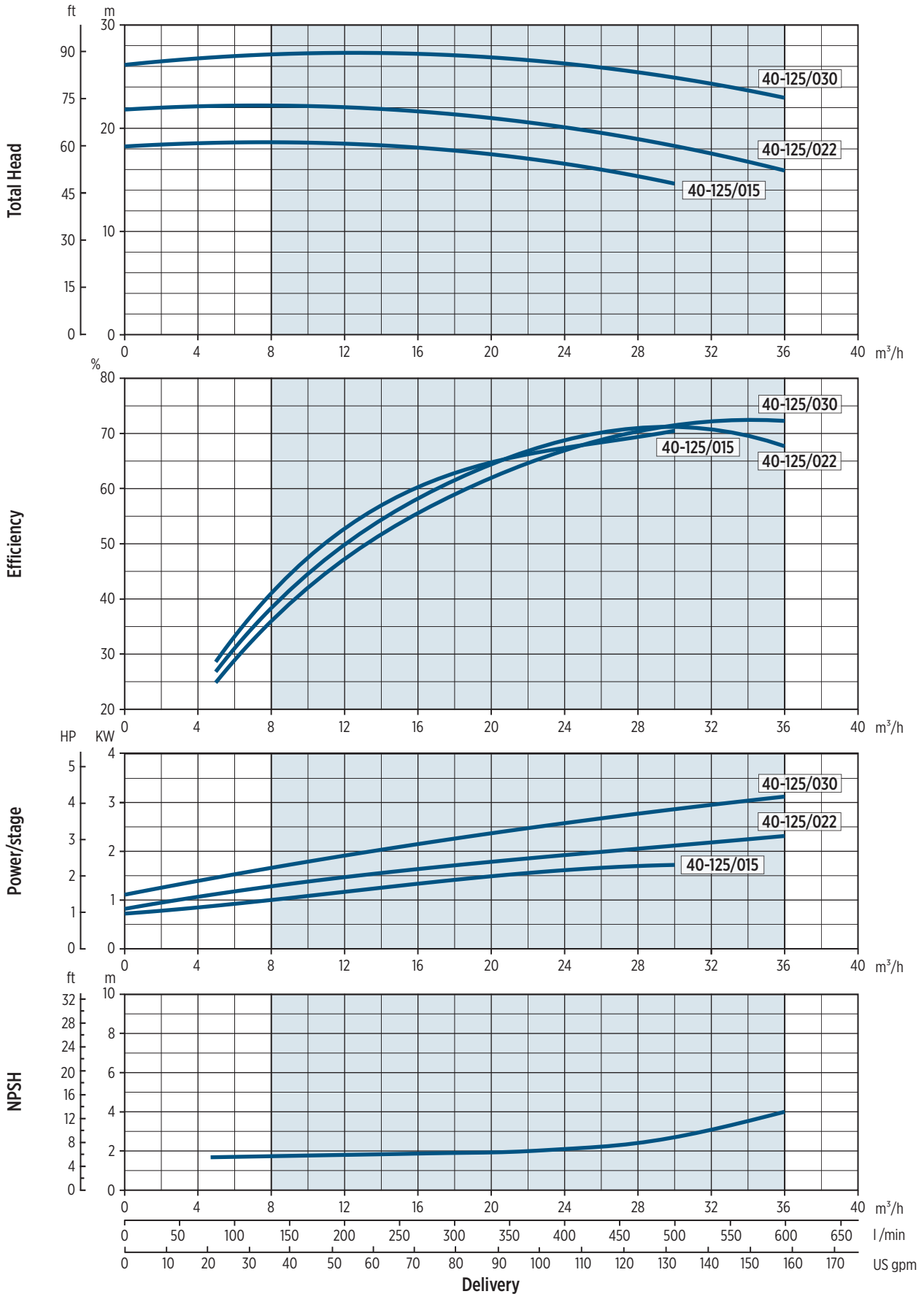

00120206 02/2019

FNC 40-160 - PERFORMANCE CURVES

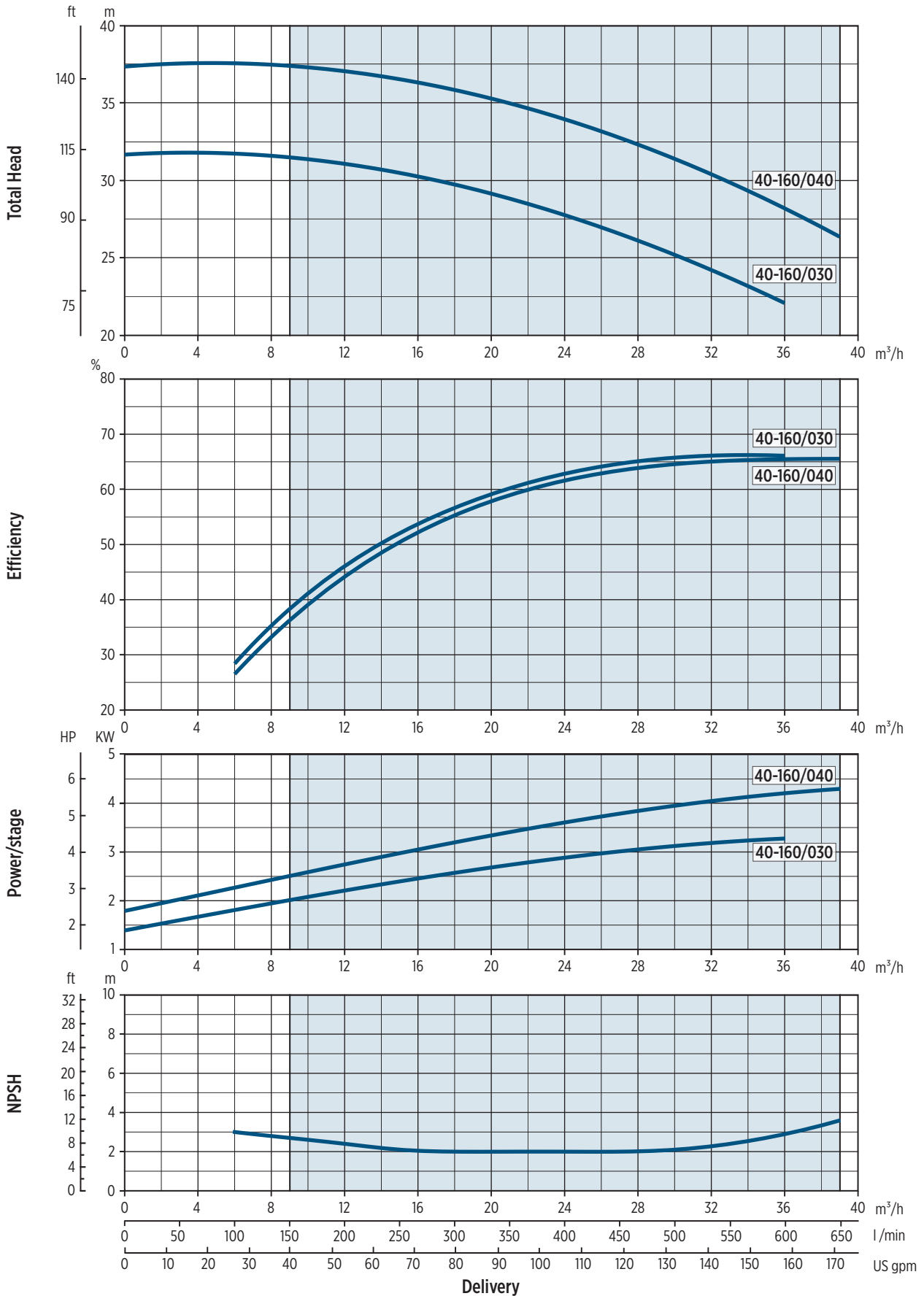

00102019



FNC/FNS 40-200 - PERFORMANCE CURVES

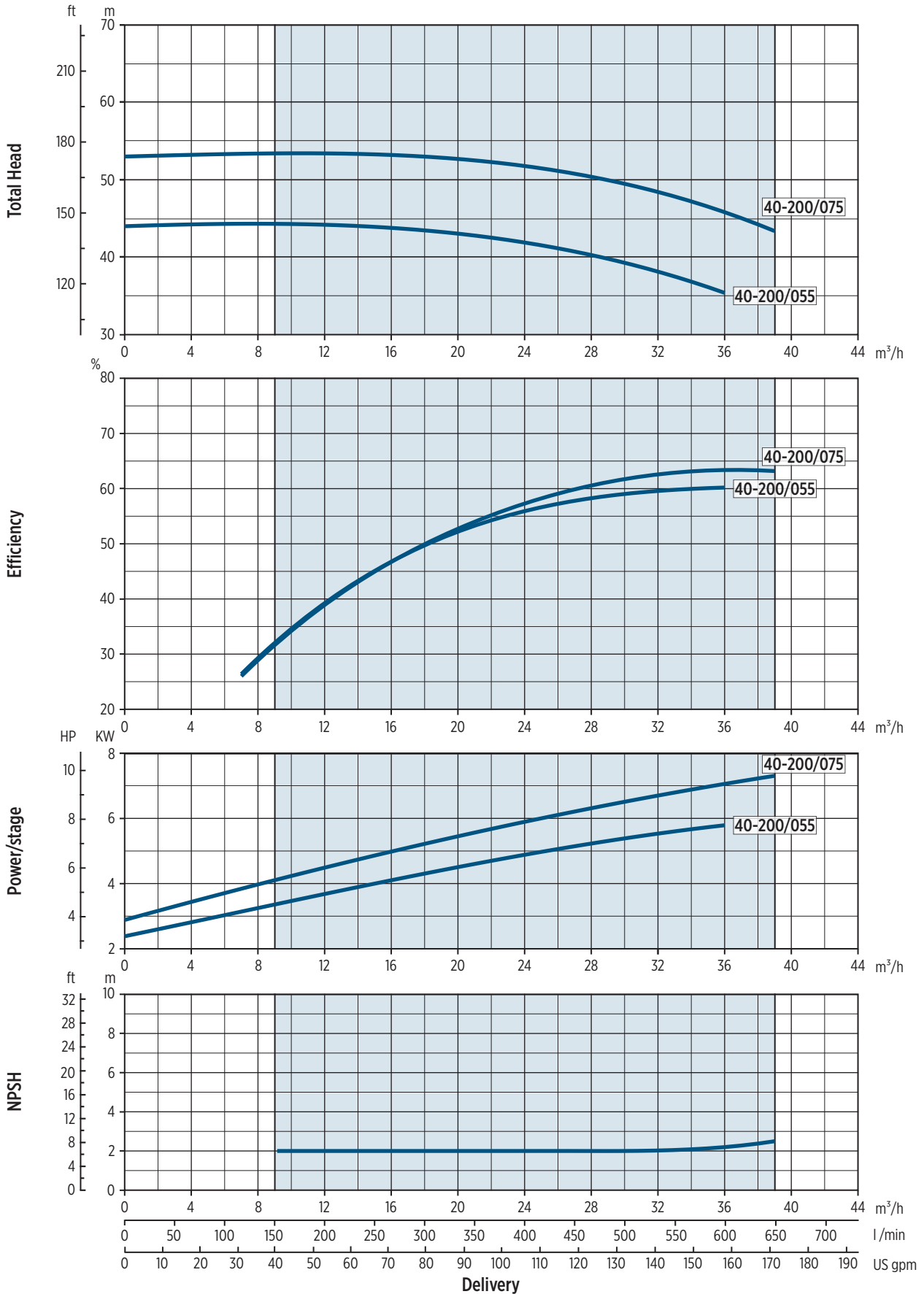

00120208 05/2019

FNC/FNS 40-250 - PERFORMANCE CURVES

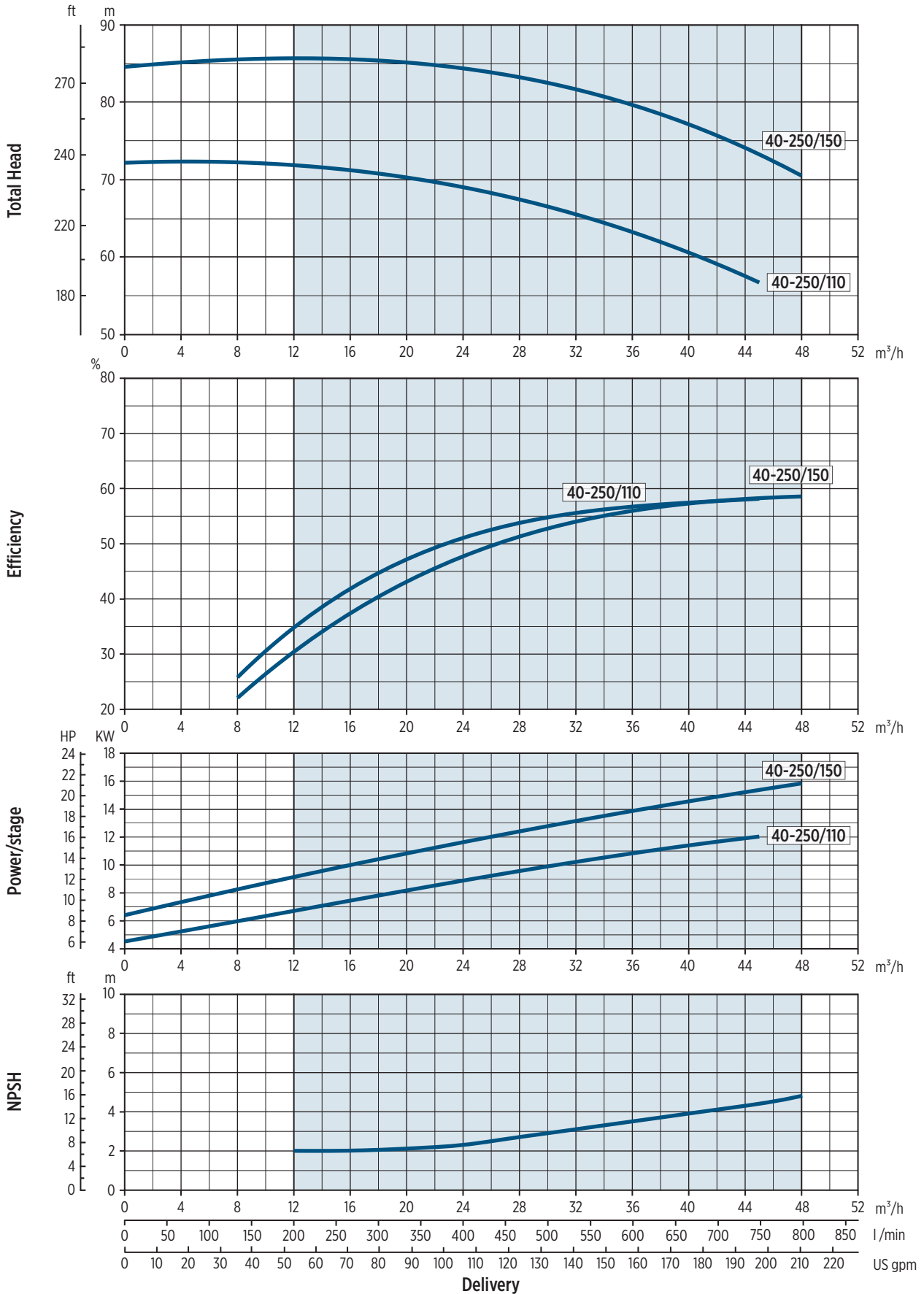

00120209 05/2019



FNC 50-125 - PERFORMANCE CURVES

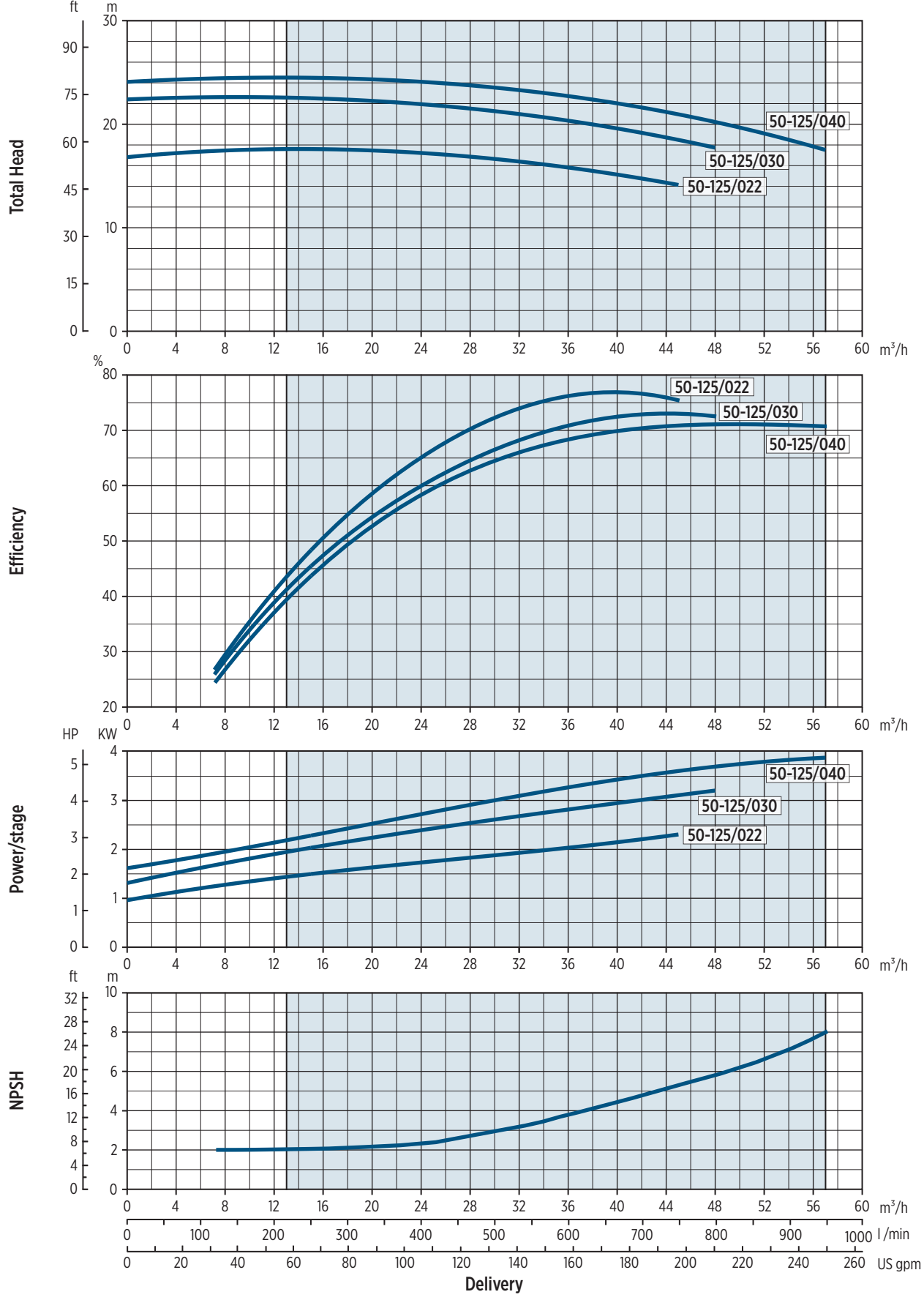

00120210 03/2019

FNC/FNS 50-160 - PERFORMANCE CURVES

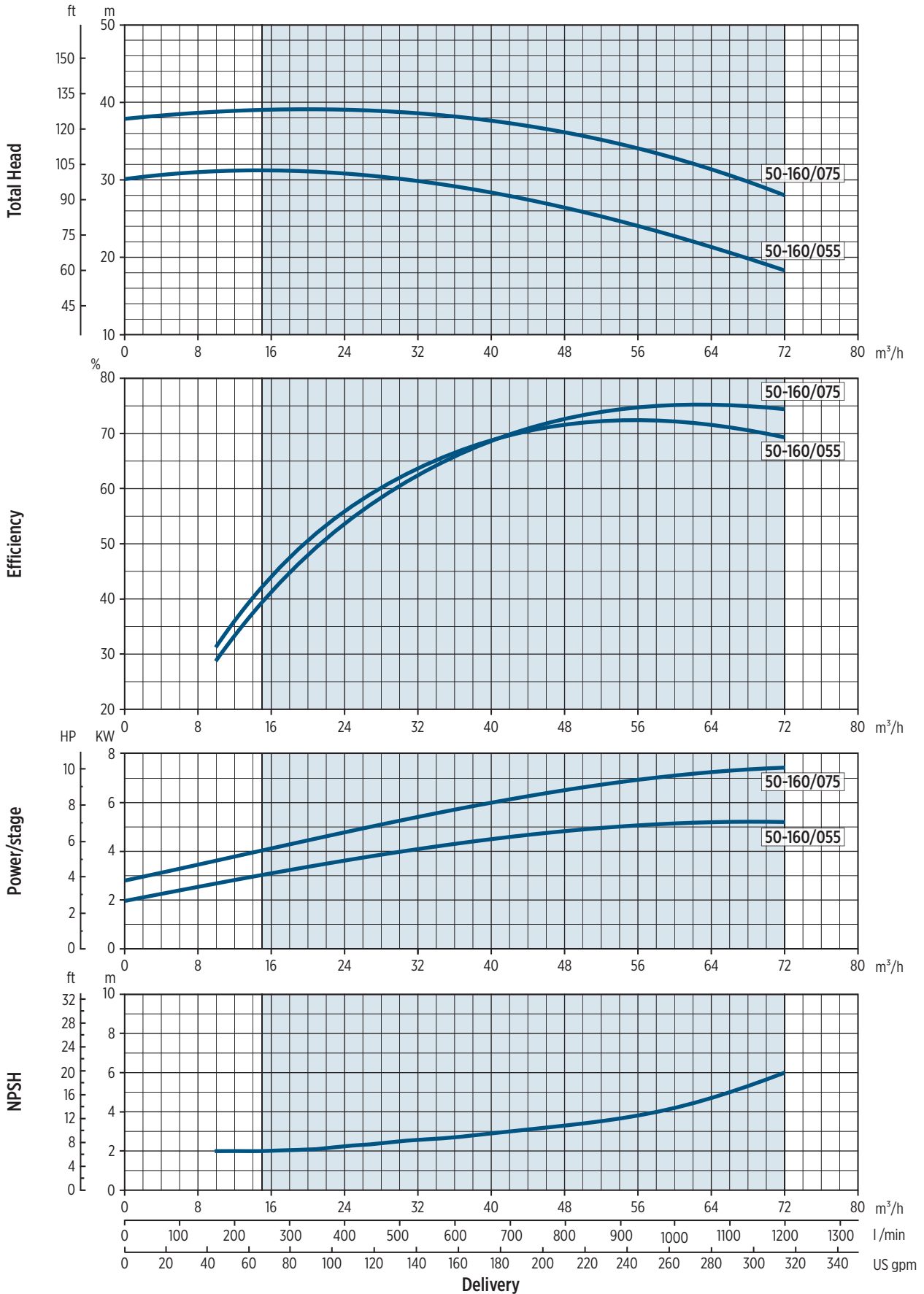

00120211 03/2019



FNC/FNS 50-200 - PERFORMANCE CURVES

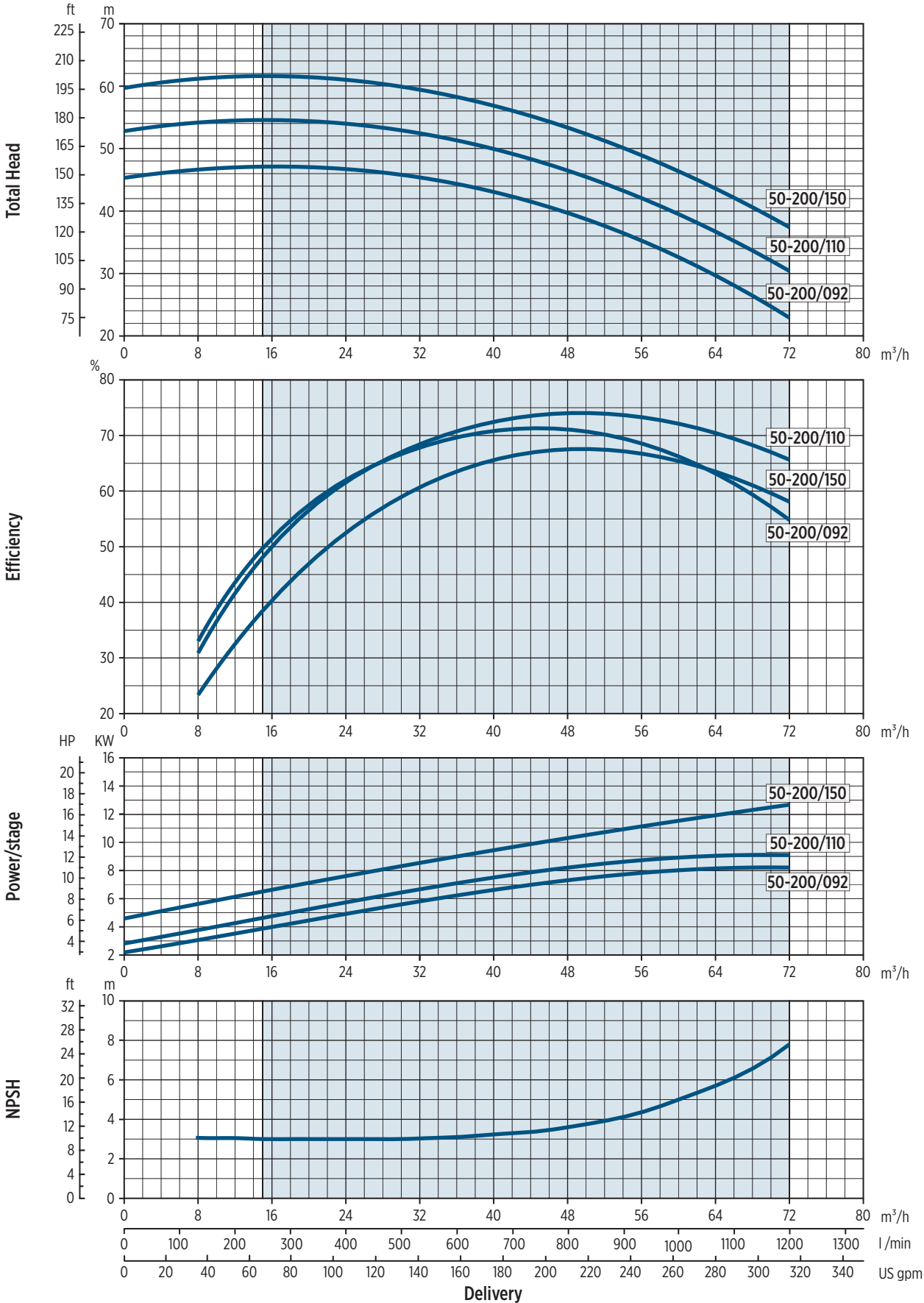

00120212 05/2019

FNC/FNS 50-250 - PERFORMANCE CURVES

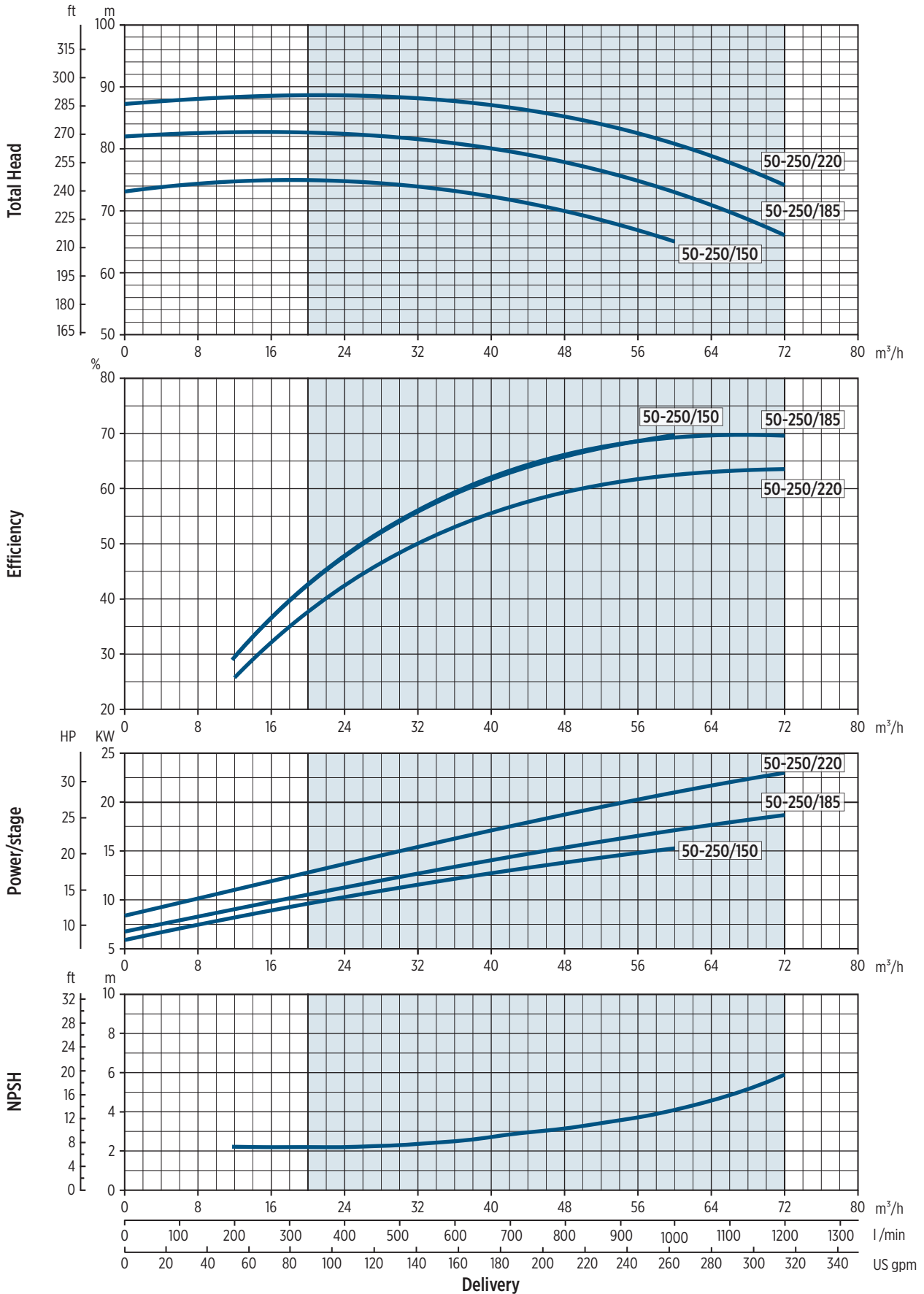

00120205/05/2019



FNC/FNS 65-125 - PERFORMANCE CURVES

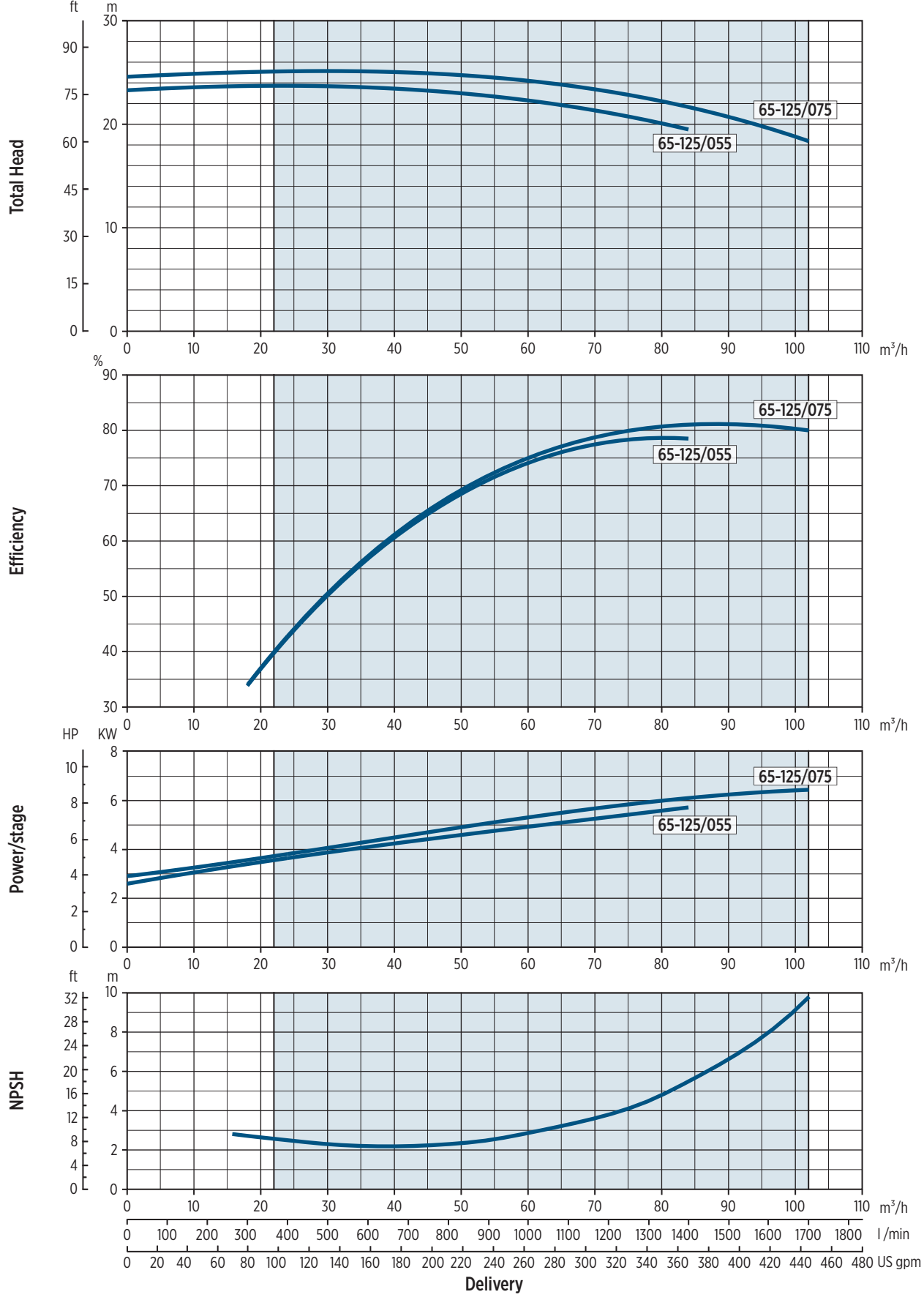

00120214.03/2019

FNC/FNS 65-160 - PERFORMANCE CURVES

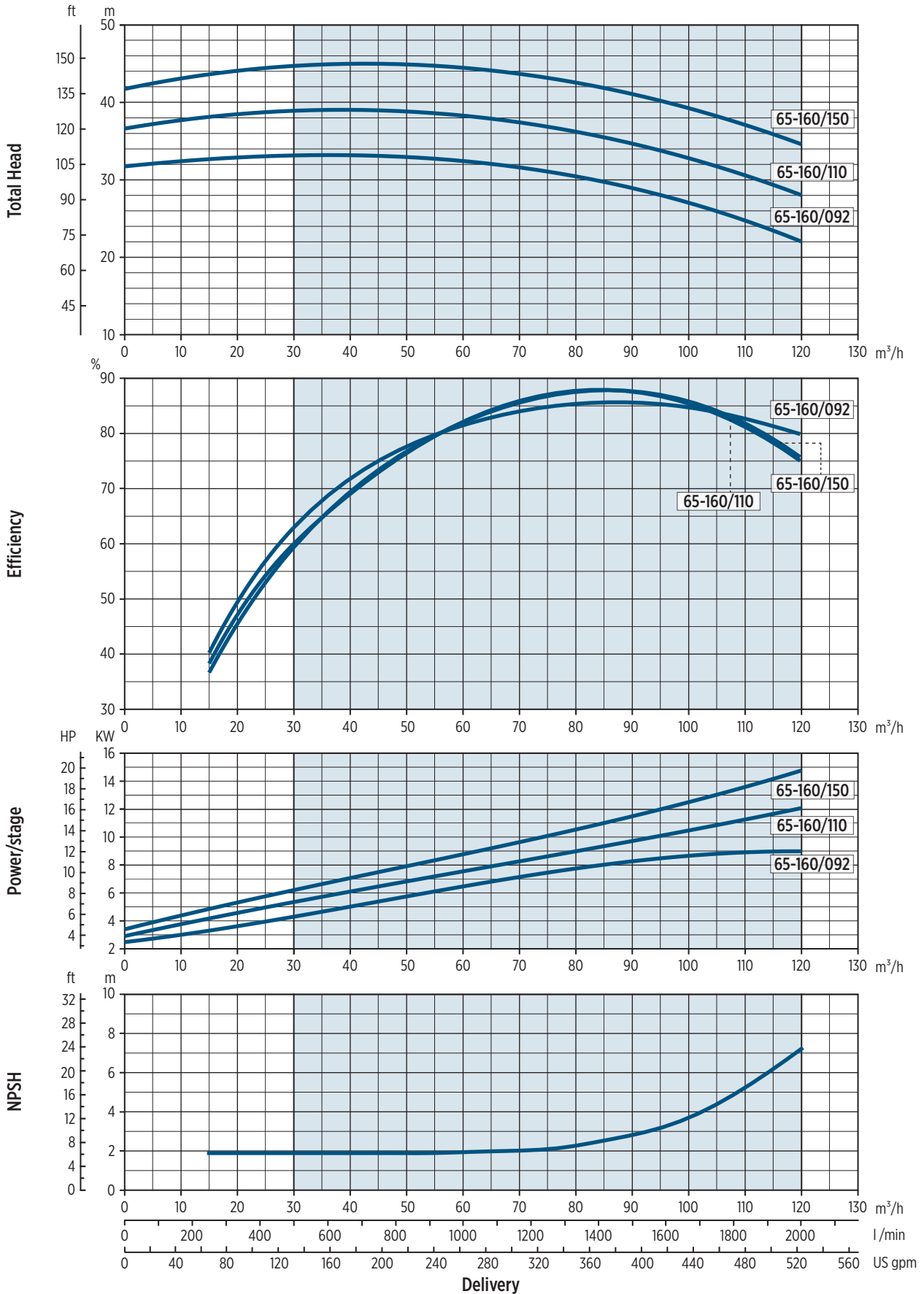

00120215 05/2019



FNC/FNS 65-200 - PERFORMANCE CURVES

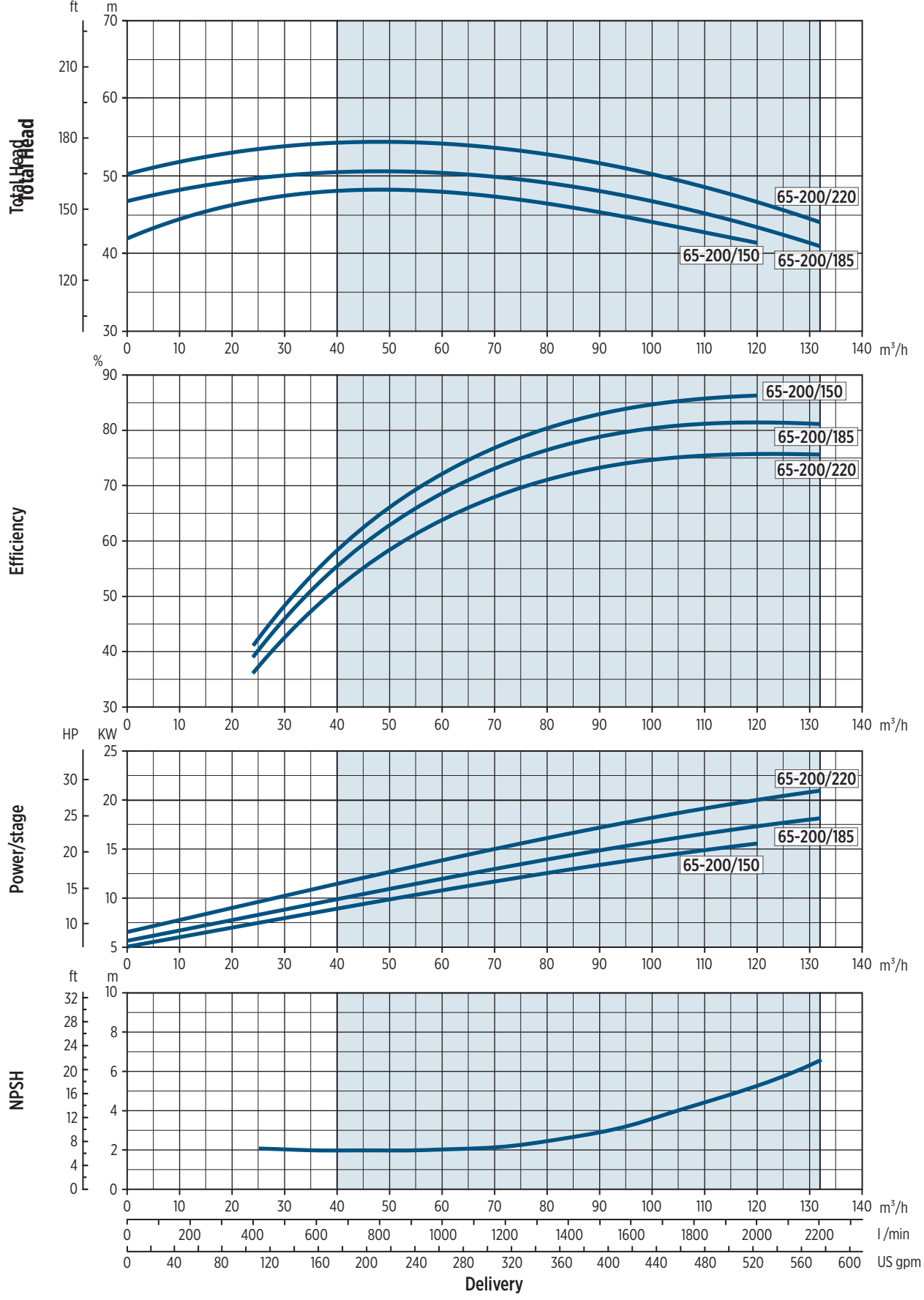

00120216 04/2019

FNS 65-250 - PERFORMANCE CURVES

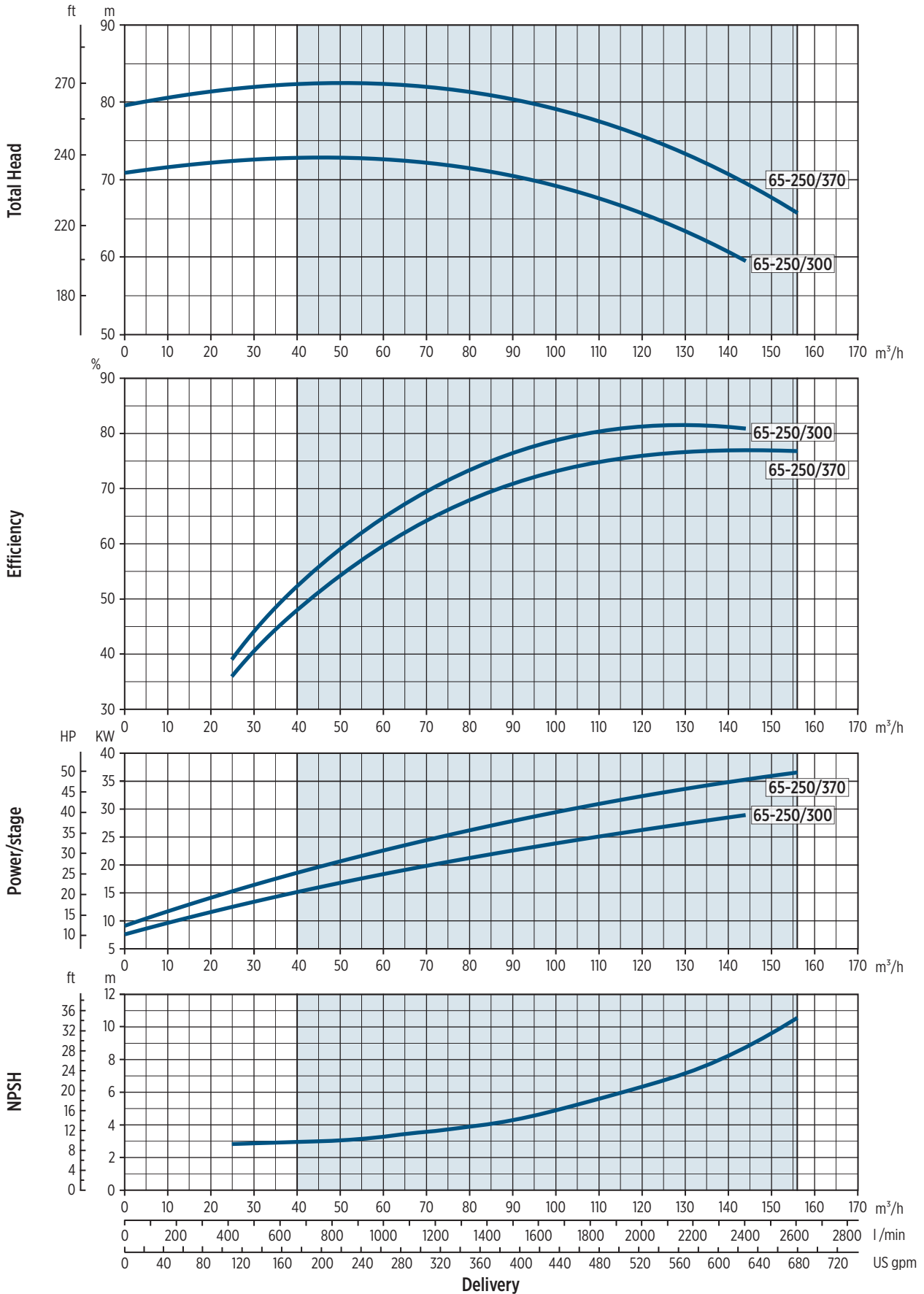

001202/03/2019



FNC/FNS 80-160 - PERFORMANCE CURVES

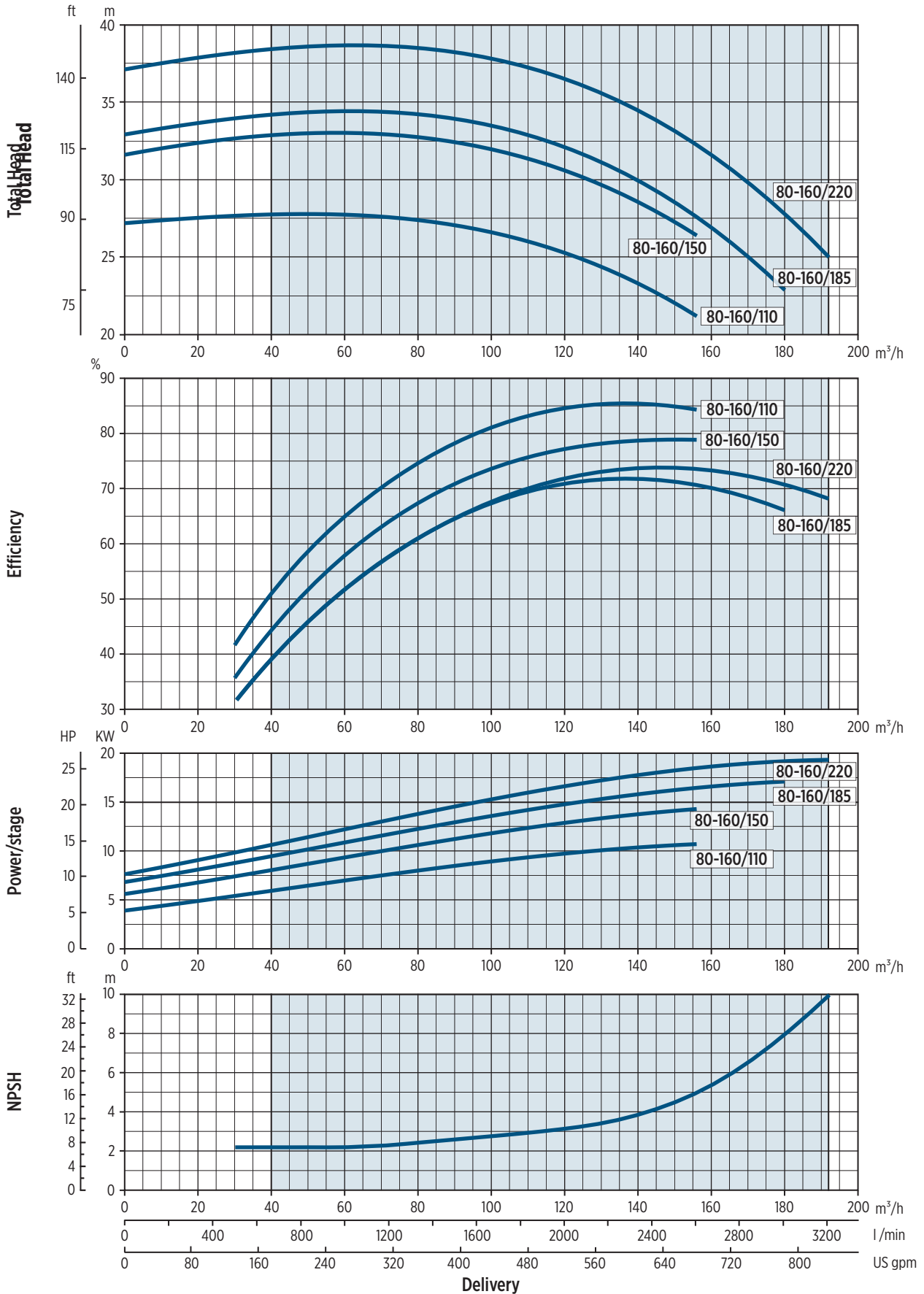

00120218 05/2019

FNS 80-200 - PERFORMANCE CURVES

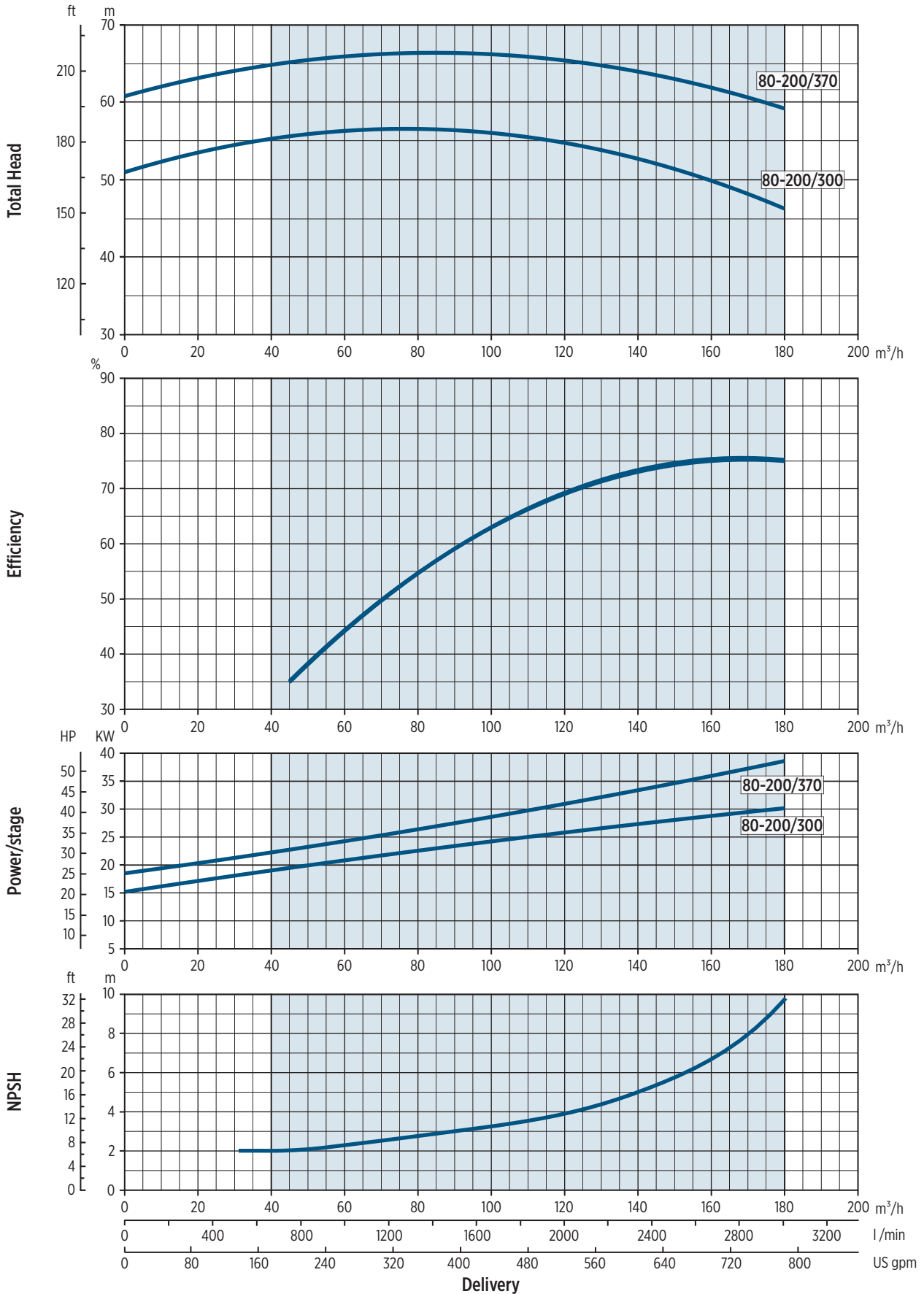

00102019 03/2019



FNS 80-250 - PERFORMANCE CURVES

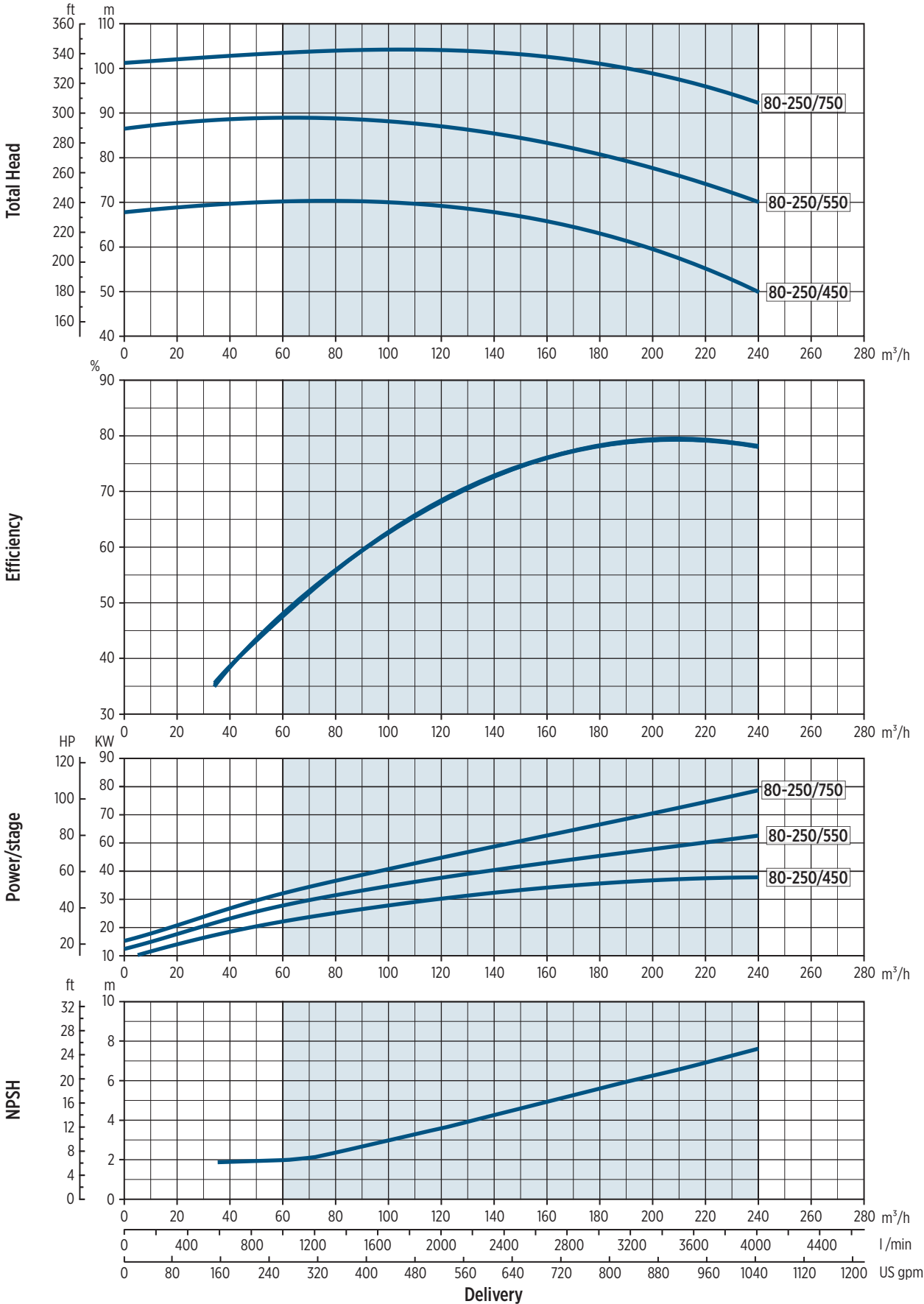

00120220 05/2019

CATALOG REVISION CHANGE NOTICE

Rev. No.	Changes	Page
01	IEC size for FNE 22 kW models changed.	18-19
	Performance curves for the 40-160 and 65-200 models updated.	29, 38
02	“Mechanical Seal Specifications” section updated.	9
	Values for 22 kW motors added.	5, 6
	“Spare Parts” for FNC updated.	10
	“Flange” table updated.	14, 16, 18
	NPSH updated from “FNC/FNE 32-125 Performance Curves”.	24
03	“Pump identification code” section modified.	4
	Removed single-phase version from “Motor specifications” section.	5
	“Technical data and dimensions” section modified.	13-16
	FNE model removed from “Performance curves”.	20-38





Franklin Electric

Franklin Electric Europa GmbH
Rudolf-Diesel-Str. 20 - 54516 Wittlich
GERMANY
Phone: +49 (0) 6571 - 105-0
Fax: +49 (0) 6571 - 105-510
Email: info@franklin-electric.de

Franklin Electric S.r.l.
Via Asolo, 7 - 36031 Dueville (Vicenza)
ITALY
Phone: +39 0444 361114
Fax: +39 0444 365247
Email: sales.it@fele.com



00105031 EN REV.03_09-2023



franklinwater.eu

Single member - Company subject to the control and coordination of Franklin Electric Co., Inc.
Franklin Electric reserves the right to amend specification without prior notice.